



User Manual

3-Phase Hybrid Inverter

KY-EST06KH~KY-EST20KH



V1.0

All Rights Reserved

No part of this document can be reproduced in any form or by any means without the prior written permission of Jiangsu KOYOE Energy Technology Co., Ltd(hereinafter “KOYOE”).

Trademarks Rights



The logo  and other KOYOE trademarks used in this manual are owned by Jiangsu KOYOE Energy Technology Co., Ltd.

All other trademarks or registered trademarks mentioned in this document are owned by their respective owners.

Software Copyrights

It is prohibited to use data contained in firmware or software developed by KOYOE, in part or in full, for commercial purposes by any means.

It is prohibited to perform reverse engineering, cracking, or any other operations that compromise the original program design of the software developed by Jiangsu KOYOE Energy Technology Co., Ltd.

About This Manual

The manual mainly introduces product information, installation guide, operation and maintenance. This manual cannot contain complete information about photovoltaic systems. You can find more information about other devices at www.koyoe.com or on the relevant component manufacturer's web pages.

Scope of application

This manual is valid for the following inverter models:

- KY-EST06KH
- KY-EST08KH
- KY-EST10KH
- KY-EST12KH
- KY-EST15KH
- KY-EST17KH
- KY-EST20KH

They will be referred to as “inverter” hereinafter unless otherwise specified.

How to Use the Manual

Before using or operating the inverter, please read this manual and other relevant documents carefully.

The contents in this manual are owned by Jiangsu KOYOE Energy Technology Co., Ltd., and shall not be reproduced or published in any form without the prior written permission of our company.

The contents of the manual may be periodically updated or revised as a result of product development. Information in this manual is subject to change without prior notice. The latest handbook is available at www.koyoe.com.

1. System Introduction	7
1.1. Product Introduction	8
1.1.1 Inverter Introduction	8
1.1.2 Energy Mete	8
1.1.2.1 Operating manual of Meter	8
2. Safety Instructions	18
2.1. PV Panels	18
2.2. Utility Grid.....	18
2.3. Battery.....	19
2.4. Inverter.....	19
2.5. Skills of Qualified Personnel	22
3. Energy Management	22
3.1. Self Use.....	22
3.2. Forced Charging.....	24
3.3. Forced Discharge	24
3.4. Peak Shaving	25
3.5. Maintenance.....	25
3.6. Emergency Charging.....	26
3.7. Off Grid	26
4. Working Stetes.....	27
4.1 Waiting	27
4.2 Checking	27
4.3 Normal	27
4.4 Fault.....	27
4.5 Upgrade	29
5. Function Description	29
5.1 Safety Function	29
5.2 Power quality response modes.....	35
5.3 Energy Conversion and Management	35
5.4 Power Derating.....	35
5.5 External Demand Response (DRMs)	36
6. Unpacking and Storing	37
6.1. Unpacking and Inspecting	37
6.2. Packing List.....	38
6.3. Inverter Storage.....	39
7. Mechanical Mounting.....	40

7.1. Safety during Mounting.....	40
7.2. Mounting Location.....	40
8. ELECTRICAL WIRING CONNECTION.....	43
8.1. Safety Instruction.....	43
8.2. Terminal Description.....	44
8.3. Electrical Connection Overview.....	46
8.4. Additional Grounding Connection.....	49
8.5. PV CONNECTION.....	52
8.6. Battery CONNECTION.....	56
8.7. AC Cable Connection.....	60
8.8. EPS Cable Connection.....	62
8.9. Communication Connection.....	62
8.10. Meter Connection.....	62
8.11. Generation Limit and Export Limit Control.....	62
8.11.1 Soft export Limit Control.....	62
8.11.2 Hard export Limit Control.....	62
8.11.3 Soft generation limit control.....	62
8.11.4 Hard generation limit control.....	62
9. Commissioning.....	64
9.1. Inspection before Commissioning.....	69
9.2. Powering on the System.....	71
9.3. LCD Introduction.....	72
10. Decommissioning.....	74
10.1. Decommissioning the Inverter.....	74
10.1.1 Disconnecting the Inverter.....	74
10.1.2 Dismantling the Inverter.....	74
10.1.3 Disposing the Inverter.....	74
11. Communication and Monitoring.....	75
11.1. Summary.....	75
11.2. Communication.....	75
11.3. RS-485 Communication.....	76
11.4. WiFi / GPRS Communication.....	76
11.5. Monitoring.....	76
12. Maintenance and Repair.....	79
12.1. Precautions during Maintenance.....	79
12.2. Safety Requirements during Maintenance.....	79

12.3. Daily Maintenance	80
13. Technical data	80
13.1 .Technical Parameters And Certificates.....	80
14. Warranty commitment	83
15. Contact Information	84
Appendix I: Common Problems	85
Appendix II: Abbreviations of Terms.....	86

1. System Introduction

KY-EST06KH/ KY-EST08KH/ KY-EST10KH/KY-EST12KH/ KY-EST15KH/ KY-EST17KH/ KY-EST20KH series inverter, also known as hybrid or bidirectional solar inverter, is suitable for energy management of photovoltaic, battery, load, power grid and other solar energy systems. Electricity from the photovoltaic panels is used for residential electricity, and excess power can be stored in batteries. When the battery is fully charged, users can send excess power to the utility grid.

When the photovoltaic power is not enough to meet the user's load demand, the battery will discharge to the load. If there is not enough energy stored in the battery, the grid will supply power to the load through the system.

The inverter with no transformer topology, and there is no isolation between DC input and AC output. The adaptive PV model must meet IEC61730 Class A. The energy management system is shown in Figure 1-1.

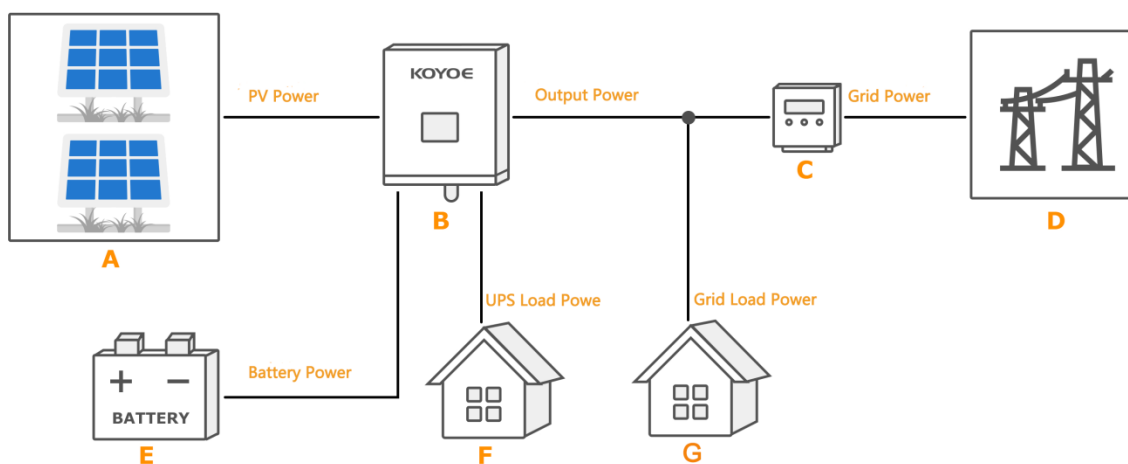

Fig.1-1 PV Energy Storage System

Item	Description	Remark
A	PV strings	Photovoltaic panel
B	Inverter	Model: KY-EST20KH
C	Energy meter(three-phase)	RS 485 communication with inverter
D	Utility grid	Grid grounding system types: TT,TN
E	Battery System	A Li-ion battery or a lead-acid battery.
F	UPS load	User load connected to the inverter EPS port.
G	Grid load	User loads connected to the grid.



Warning!

-For the TT utility grid, the N line voltage to ground must be 30V or less.

- The maximum power of home load and EPS load must be less than the rated power of inverter.

1.1. Product Introduction

1.1.1 Inverter Introduction

Model Description

The inverter model description is as follows (Take KY-EST20KH as an example):

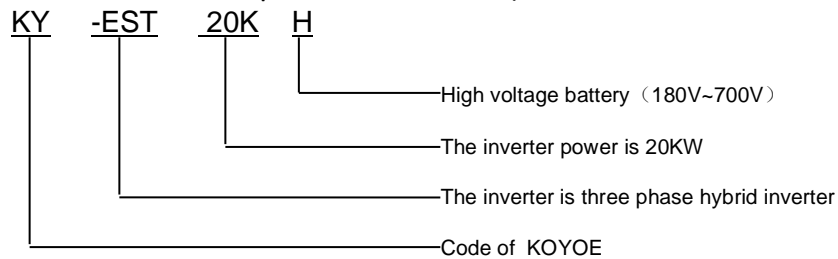

Model	Nominal Output Power	Nominal Grid Voltage
KY-EST06KH	6000W	3/N/PE,230/400V
KY-EST08KH	8000W	
KY-EST10KH	10000W	
KY-EST12KH	12000W	
KY-EST15KH	15000W	
KY-EST17KH	17000W	
KY-EST20KH	20000W	

Appearance

The following figure shows the inverter appearance, which is for reference only. The actual product that you receive may differ.

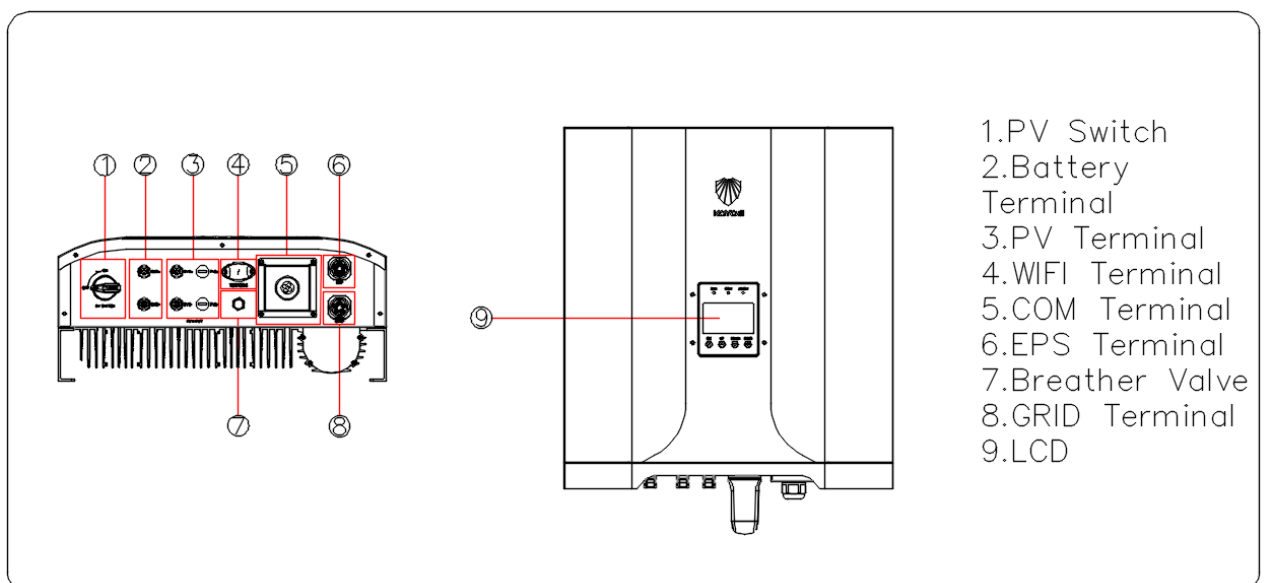

Fig1-2.Appearance(KY-EST06-10KH)

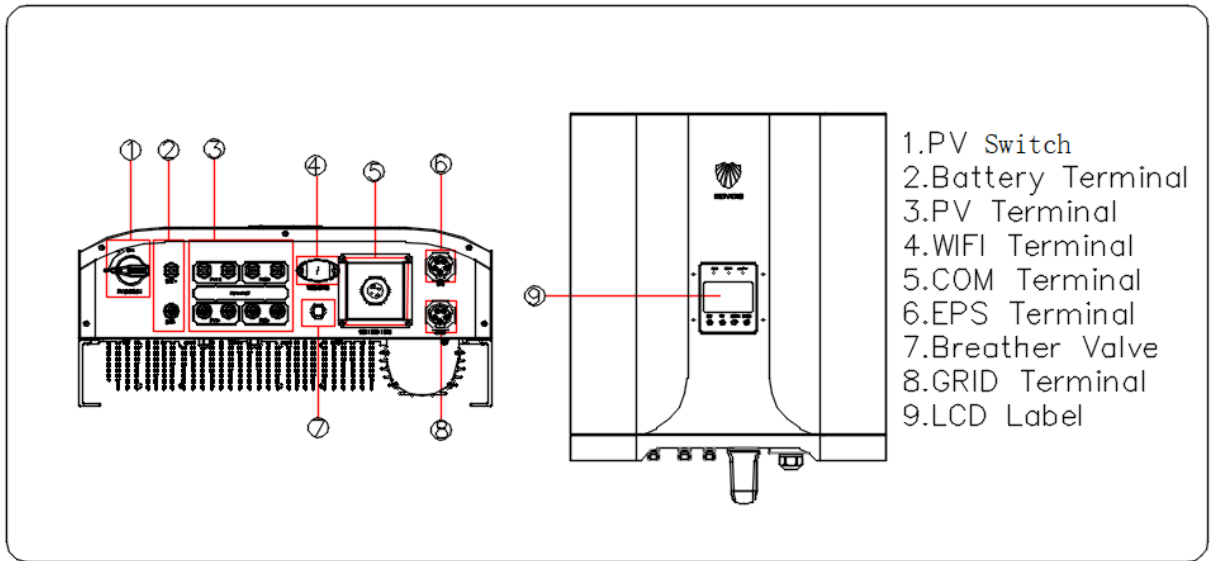

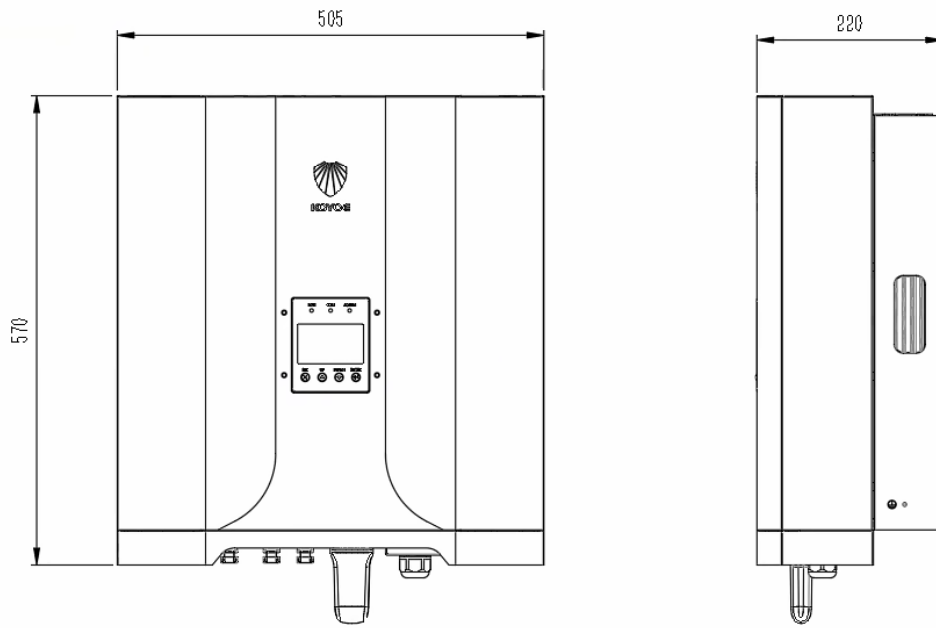

Fig1-3.Appearance(KY-EST12-20KH)

 **Be careful!**
This inverter contains a PV switch. For safety reasons, it is recommended to have a DC switch between the PV array and the inverter PV input terminals (mandatory in some countries).

Dimensions

The following figure shows the dimensions of the inverter. See Figure 1-4 and the following table for the description of LCD panel.



Dimensions KY-EST06-10KH(unit: mm)

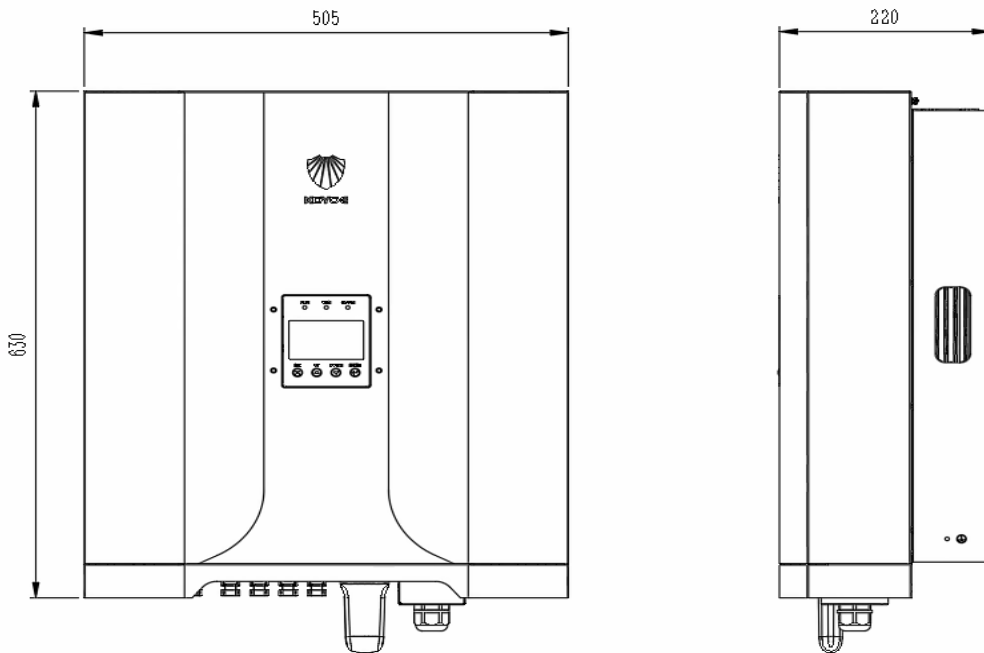

Dimensions KY-EST12-20KH(unit: mm)

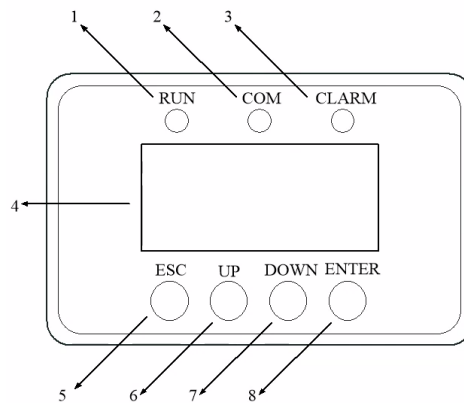

Fig1-4.LCD panel

No.	Name	Description
1	Run LED(Green)	After the inverter is powered on, the LED flashes. When the inverter is in normal mode, the LED will always be bright
2	COM LED(Yellow)	When the inverter communicates through WIFI,GPRS and upper computer, the LED flashes
3	ALARM LED(Red)	When an alarm occurs, the LED flashes. When the inverter fails, the LED will always be on
4	LCD Screen	To display the information
5	ESC Key	Exit the current menu
6	Up Key	Page up or move cursor
7	Down Key	Page down or move cursor
8	Enter Key	Enter the current menu

1.1.2 Energy Meter

The Energy Meter is installed next to the grid main switch to detect the electrical measured values at the grid-connected point. It communicates with the inverter via an RS485 connection. The dimensions are shown below. Please refer to the wiring guide for electricity meters. The meter mode is: SDM630MCT(40mA) ,The meter manufacture is EASTRON.

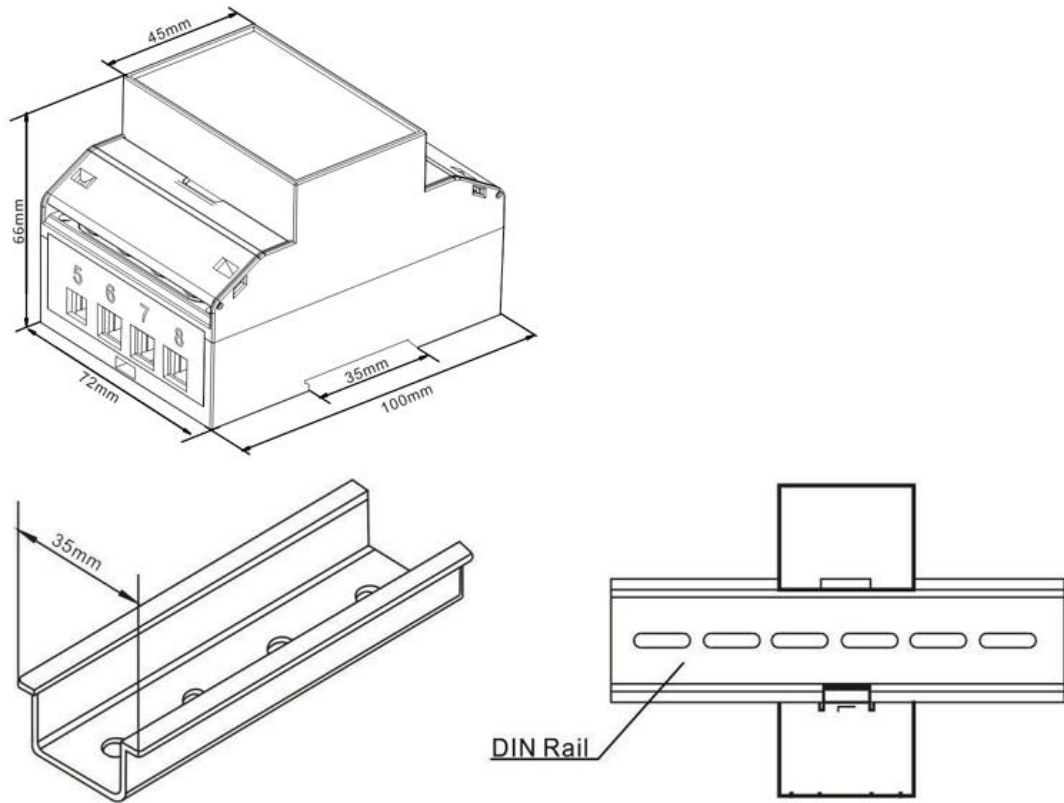
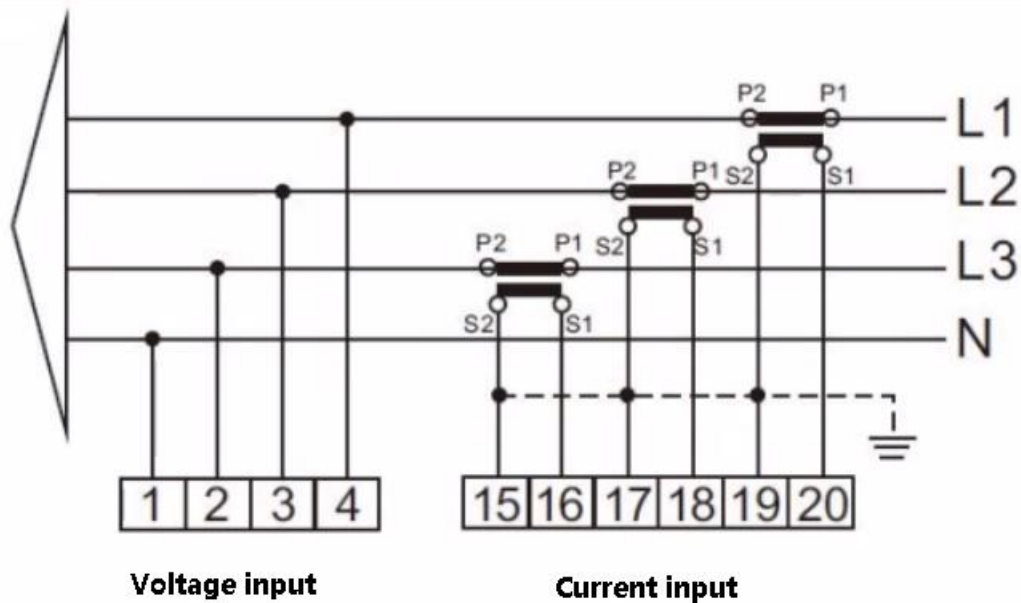

Fig1-5.Three-phase Meter Dimension (unit: mm)

3P4W 3CT



power supply

voltage input

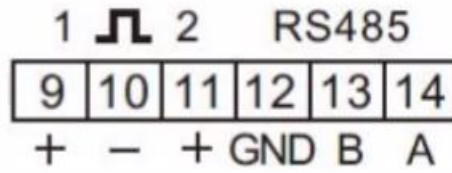
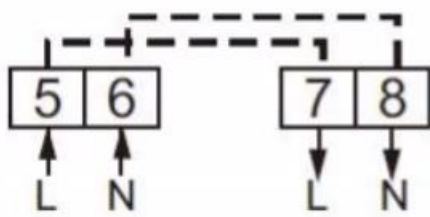

The following is the electrical connection diagram of the electricity meter. For detailed operation of the electricity meter, please refer to the operation manual of the electricity meter in the accessories. If you have any questions, please contact our customer service.

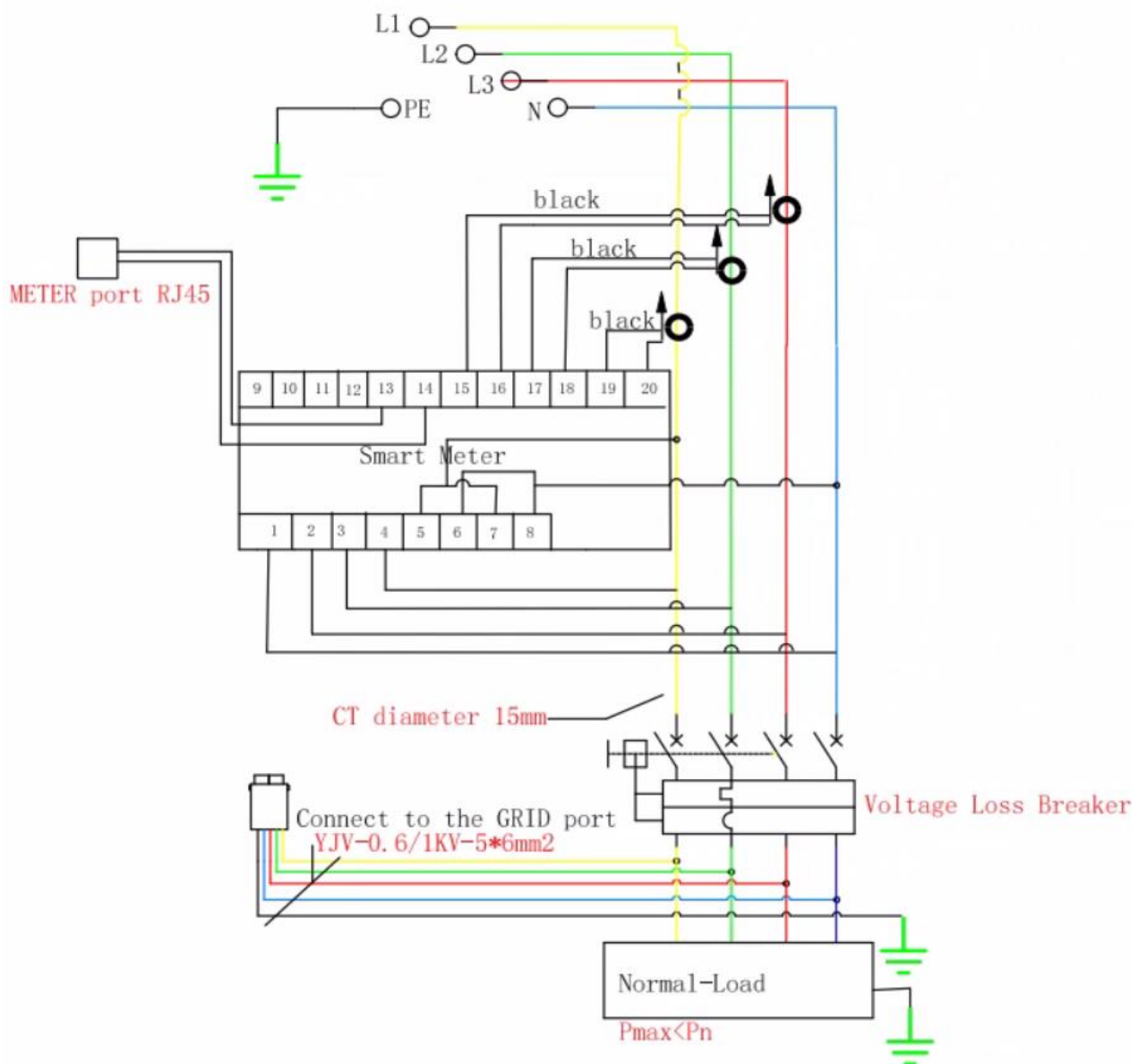

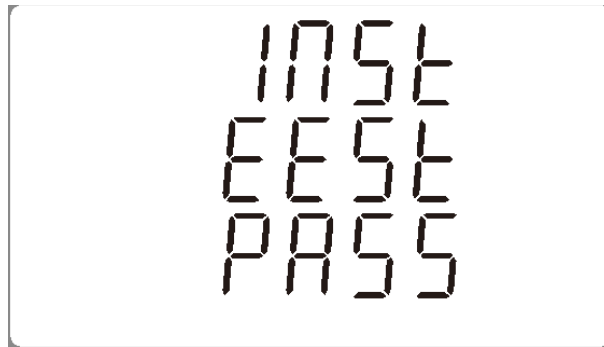

1.1.2.1 Operating manual of Meter

If the wiring is OK, the instrument will display the following results on the screen after automatic power on self-test.

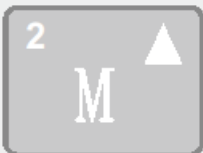
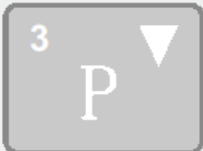

The functions of the keys on the right side of the instrument are shown in the figure below.

	<p>Selects the Voltage and Current display screens. In Set-up Mode, this is the “Left” or “Back” button. 1 will be used in the next following.</p>
	<p>Select the Frequency and Power factor display screens. In Set-up Mode, this is the “Up” button. 2 will be used in the next following.</p>
	<p>Select the Power display screens. In Set-up Mode, this is the “Down” button. 3 will be used in the next following.</p>
	<p>Select the Energy display screens. In Set-up mode, this is the “Enter” or “Right” button. 4 will be used in the next following.</p>



Each successive press of the button selects a new parameter:

	Phase to neutral voltages.
	Current on each phase.
	Phase to neutral voltage THD% of 2nd to 19th.
	Each phase Current THD% of 2nd to 19th.



Each successive press of the button  selects a new parameter:

	Frequency and Power Factor (total).
	Power Factor of each phase.
	Maximum Current Demand.
	Maximum Power Demand.

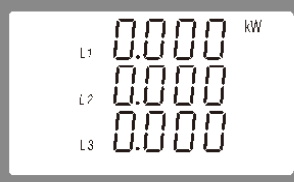
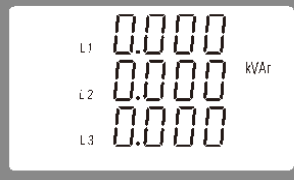
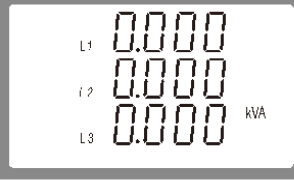
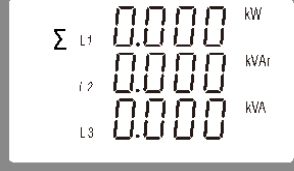

Each successive press of the button selects a new parameter:

	Instantaneous Active Power in kW.
	Instantaneous Reactive Power in kVar.
	Instantaneous Volt-Amps in KVA.
	Total kW, kVarh, kVA.



Each successive press of the button selects a new parameter:

Σ 0000 kWh 0000	Total active energy in kWh.
Σ 0000 kWh 0000	Total reactive energy
Imp 0000 kWh 0000	Import active energy in kWh.
Exp 0000 kWh 0000	Export active energy in kWh.
Imp 0000 kWh 0000	Import reactive energy
Exp 0000 kWh 0000	Export reactive energy

2. Safety Instructions

The inverter is strictly complying with the relevant safety regulations of product design and testing. In order to use this product more safely and reliably, the following lists the information related to different categories of safety. In the process of installation, operation and maintenance, please carefully read and observe the instructions and precautions of the inverter, otherwise it will cause loss of personal and property.

	<p>NOTICE!</p> <ul style="list-style-type: none">-The safety instructions in this manual cannot cover all the precautions that should be followed. Perform operations considering actual on site conditions.-KOYOE shall not be held liable for any damage caused by violation of the safety instructions in this manual.
---	---

2.1. PV Panels

Users must ask professionals to install the photovoltaic panels according to the user manual. Please pay attention to the following matters during installation:

- Photovoltaic panels generate electricity when they are exposed to sunlight and can cause fatal voltages and shocks.
- The inverter is a multi-power system. Operators must wear appropriate personal protective equipment: safety helmet, insulation wire, gloves, etc.
- The operator must use measuring equipment to ensure that the output cable of the PV panel is free of voltage before contacting it.
- All the warnings on the PV panel and in its manual must be followed.

	<p>Warning!</p> <ul style="list-style-type: none">-The inverter must only be operated with PV strings of protection class II in accordance with IEC 61730, application class A.-It is not permitted for the positive pole or the negative pole of the PV strings to be grounded.- Damages to the product due to a faulty or damaged PV installation are not covered by warranty.
---	---

2.2. Utility Grid

Please comply with the relevant regulations of power grid.

	<p>Be careful!</p> <ul style="list-style-type: none">- All electrical connections must comply with local and national standards.-Only with the permission of the utility grid, the inverter can be connected to the utility grid.
---	---

2.3. Battery

Please use the battery recommended by our company and pay attention to the following :

	<p>DANGER!</p> <ul style="list-style-type: none">- A short circuit or incorrect installation of a battery can release energy and may result in a combustion or fire hazard.- There may be fatal voltage in the battery terminals and cables of the inverter. Contact with the cables and terminals in the inverter may cause serious personal injury or even death.
---	---

	<p>Warning!</p> <p>Provide sufficient ventilation for the battery system to prevent flames and sparks from the explosive hydrogen gas that the batteries release.</p> <p>Due to the dangers of hydrogen gas and battery electrolyte:</p> <ul style="list-style-type: none">-locate batteries in a designated area, complying with the local regulations.-protect the enclosure against destruction.-do not open or deform the battery.-whenever working on the battery, wear suitable personal protective equipment (PPE) such as rubber gloves, rubber boots and goggles.-rinse acid splashes thoroughly with clear water for a long time and consider consulting a doctor.
---	---

	<p>Warning!</p> <ul style="list-style-type: none">-Improper settings or maintenance can permanently damage the battery.-Incorrect inverter parameters will lead to the premature aging of battery.
---	--

2.4. Inverter



DANGER!

Improper handling can be a danger of electric shock.

Do not open the shell at any time. Opening the shell without authorization will not continue to enjoy the warranty.



Warning!

Inverter operation is prohibited improper operation.

- Do not pull out PV connectors, AC connectors and battery connectors when the inverter is running.

- When turning off the inverter, all power supplies of the inverter, including PV, grid and batteries, must be turned off and wait 10 minutes before operating the inverter.

- Before pulling out any connectors, you must ensure that the connectors have no voltage or current.



Warning!

After completion of installation, all safety instructions, warning labels and nameplates on the inverter must meet the following conditions:

-Must be clearly legible.

-Should not be removed or covered.



Warning!

Risk of burns due to hot components .

-Do not touch any hot parts (such as heat sinks) during operation.

-Only the LCD panel and the DC switch can safely be touched at any time.



Warning!













- Only professionals can change the type Settings of safety regulations.

- Unauthorized changes to safety regulations lead to damage of the inverter will not enjoy warranty service.

- Please be aware of the risk of static electricity from damaging the inverter.

- Do not disassemble the inverter and contact the internal devices.

- Connectors that contact the inverter directly while the inverter is running are prohibited.

Label	Description
	Caution Failing to observe a warning indicated in this manual may result in injury.
	Danger of high voltage and electric shock!
	Danger of hot surface!
	Components of the product can be recycled.
	This side up! The package must always be transported, handled and stored in such a way that the arrows always point upwards.
	No more than six (6) identical packages being stacked on each other.
	Product should not be disposed as household waste.
	The package/product should be handled carefully and never be tipped over or slung.
	Refer to the operating instructions.
	Keep dry! The package/product must be protected from excessive humidity and must be stored under cover.
	Inverter will be touchable or operable after minimum 10 minutes of being turned off or totally disconnected, in case of any electrical shock or injury.
	CE Mark.

Attention!

- When connecting the input and output of the inverter, it is necessary to connect the ground wire of the inverter first, and then connect the DC input and AC output. When disconnecting the inverter wiring, the inverter ground wire must be finally disconnected.
- Need permission from the local utility prior to connecting the inverter to the utility grid and hire qualified personnel.
- Observe all documentation that accompanies the inverter.
- Installations maintenance and installed should be carried out by competent persons, who have sufficient skills and training to apply safe methods of work to install.
- There is no maintainable part in the inverter. If there is any problem, it must be maintained by professionals.
- All electrical installations must be done in accordance with the National Wiring Rules of Standard and local code 62109.
- Non-isolated inverters : the PV modules should have an IEC61730 Class A rating.
- Inverters may be over 20kg. Please be careful when handling and lifting. Equipment or parts weighing more than 18 kg shall be equipped with lifting and handling tools or as indicated in the manufacturer's documentation.
- Software version information can be read by LCD or the upper computer software.
- The inverter is non-isolated between DC input and AC output. Product identification must be clearly visible after installation.
 - Risk of Electric Shock, Do Not Remove Cover. No User Serviceable Parts Inside. Refer Servicing To Qualified Service Personnel.
 - When the photovoltaic array is exposed to light, it supplies a dc voltage to this equipment.
 - Please note that PV input voltage must be less than 1000V . Too high voltage could cause damage to the inverter.
- Please avoid direct sunlight to the inverter.
- When the inductive load of the electric model is connected to the off-grid port, please note that the instantaneous peak current of load starting shall not be greater than two times of the RMS current of different models (6KW-206A,8KW-24A,10KW-30A,12KW-36A,15KW-44A,17KW-50A,20KW-62A) .

2.5. Skills of Qualified Personnel

All installation of the inverter shall be carried out by professionals, and the following conditions shall be met:

- Have received training on installation, commissioning and hazard management of electrical system;
- Be familiar with the contents of this manual and other relevant documents;
- Know local regulations.

3. Energy Management

Depending on your configuration and layout, the inverters usually have the following operation modes:

- 1) Self use (It is necessary to connect the Grid and save it after power failure)
- 2) Forced Charging (It is necessary to connect the Grid and not save it after power failure)
- 3) Forced Discharge (It is necessary to connect the Grid and not save it after power failure)
- 4) Peak Shaving
- 5) Maintenance
- 6) Emergency Charging
- 7) Off Grid

The user can set the inverter to the above working modes according to the actual needs. The detailed mode settings and functions are described as follows:

3.1. Self Use

The energy generated by the photovoltaic system shall first meet its own load consumption, then the excess energy is used to charge the battery, and finally the remaining energy can limit the power fed into the power grid by setting and adjusting the power of the network, as shown in the figure below:

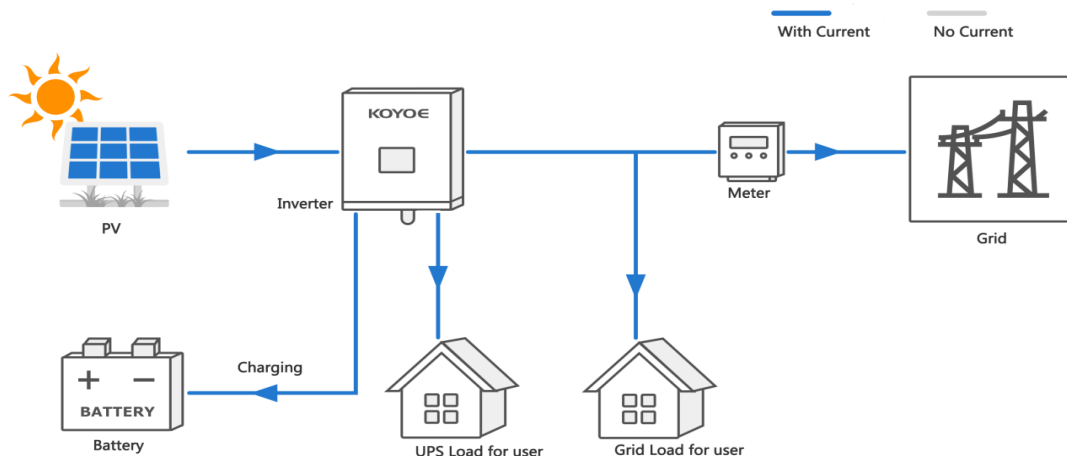

The mode setting process is as follows:

1) Press "ENTER" in the main interface to enter the following menu, and then press "UP" and "DOWN" to select "setting".

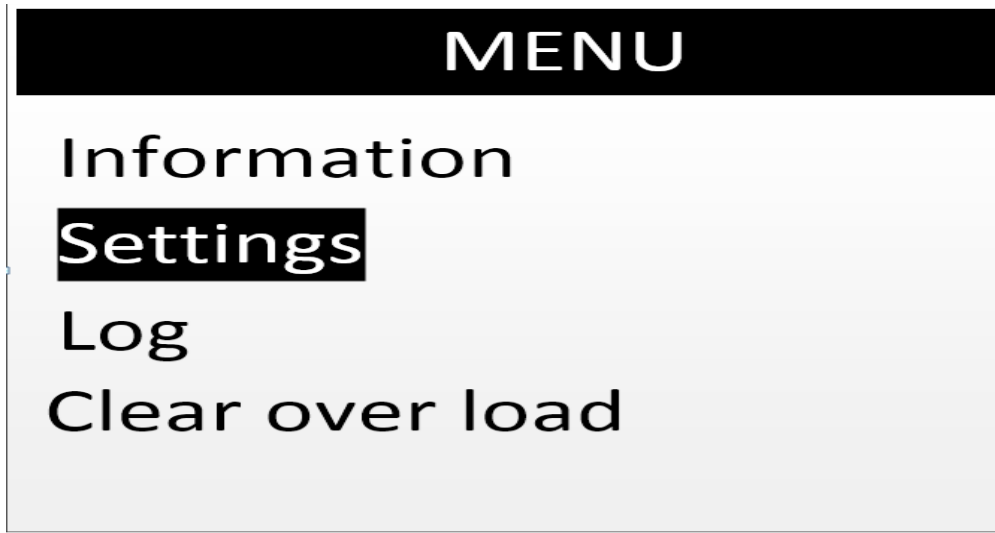

2) Press "ENTER" in the above interface to enter the following menu, and then press "UP" and "DOWN" to select "Mode setting".

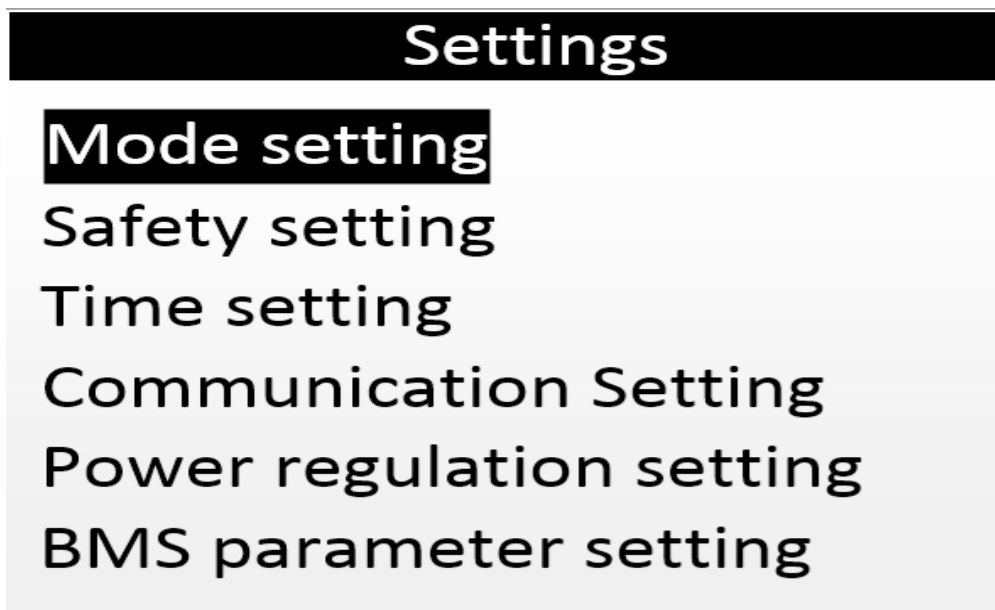

3) Press the "ENTER" button in the above interface to enter the password interface, as shown in the following menu. The default password is "1001". Press the "ENTER" button to select the cursor and add or subtract the value through the "UP" and "DOWN" buttons, then press the "ENTER" button again to confirm the value at the optical mark, then move the cursor to "OK", and press "ENTER" to confirm the input.



3) In the above interface, after entering the password, press the "ENTER" key to enter the following menu. The interface will display the current working mode. Press the "ENTER" key to select the required working mode through the "UP" and "DOWN" keys. Press the "ENTER" key again to confirm the selected mode, move the cursor to "OK", and press the "ENTER" key to confirm the input.

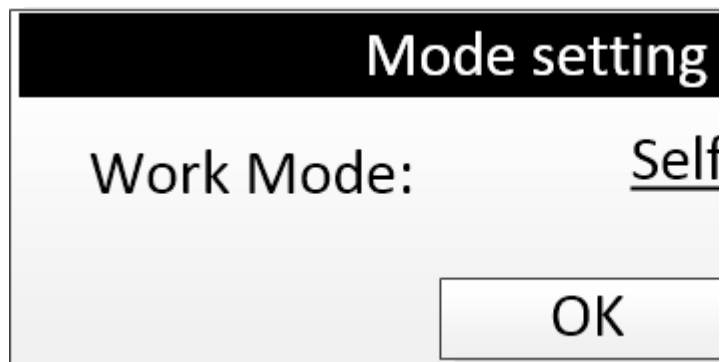

5) After the above operations, press the "ESC" key to return to the main interface to observe the operation state after changing the mode.

3.2. Forced Charging

This mode must take effect after being connected to the grid. In the forced charging mode, the inverter selects the appropriate power to charge the battery according to the allowable charging current of BMS and the calculated value of energy management. When the SOC is charged to the upper limit or the working mode is changed, it exits the forced charging mode.

In mode selection, please select the contents shown below to set the forced charging mode. For other steps, please refer to 3.1.

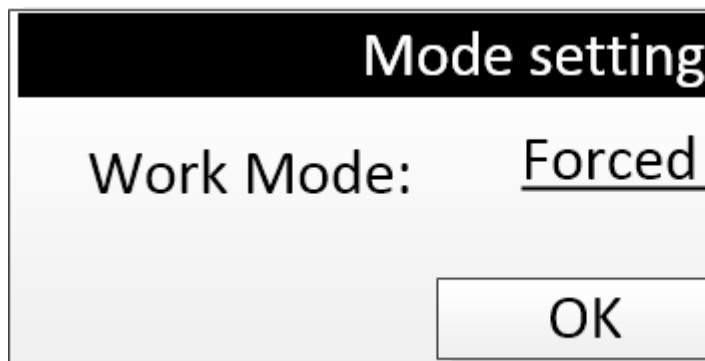

3.3. Forced Discharge

This mode must take effect after being connected to the power grid. In the forced discharge mode, the inverter selects the appropriate power to feed into the power grid according to the allowable discharge current, SOC and energy management calculation value of BMS. After receiving the BMS stop discharge command or changing the working mode, exit the forced discharge mode.

In mode selection, please select the content shown in the figure below to set the strong playback mode. For other steps, please refer to 3.1.

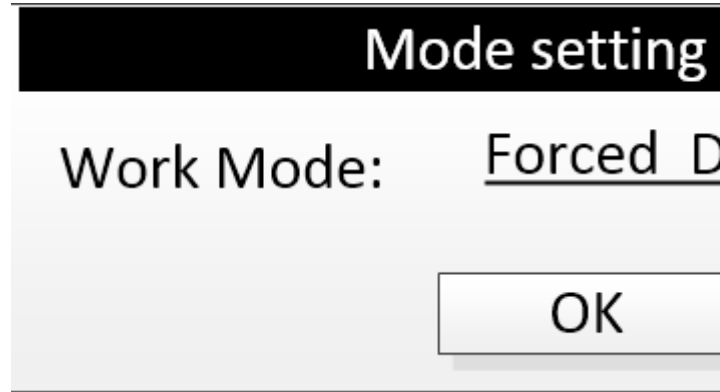

3.4. Peak Shaving

This mode must take effect after being connected to the grid. In peak shaving mode, the inverter can set up up to 10 groups of discontinuous charge and discharge time periods within 24 hours; In this mode, the power of load power supply, charge or discharge will be preferentially adjusted according to the allowable value of BMS and current energy management.

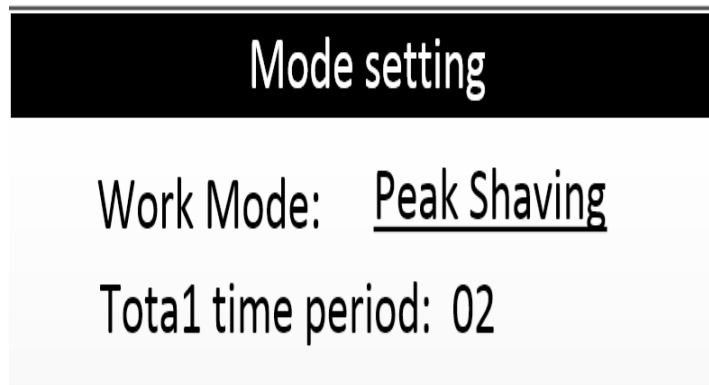

3.5. Maintenance

This mode must take effect after being connected to the grid. In the maintenance mode, the inverter will charge the battery until the SOC is charged to 100% or set to other modes, and automatically exit this mode. The charging power is adjusted according to the allowable value of BMS and the current energy management.

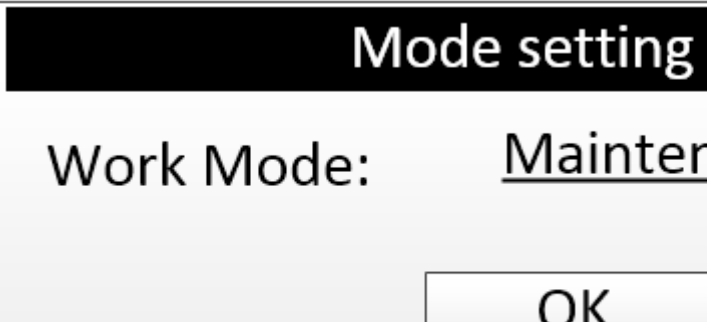

3.6. Emergency Charging

This mode must take effect after connecting to the power grid. In the emergency charging mode, the inverter will charge the battery according to the start or stop charging command of BMS until the SOC is charged to the upper limit value or set to other modes, and then automatically exit this mode. The charging power is adjusted according to BMS value and current energy management.

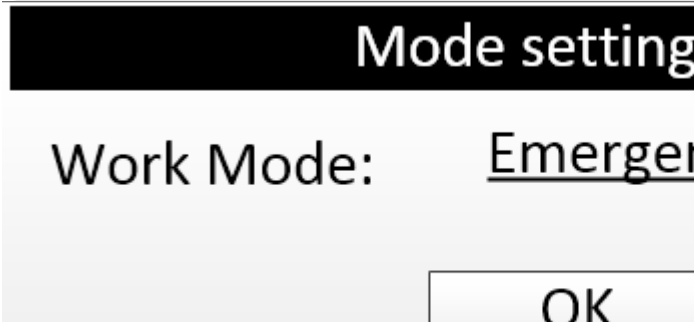

3.7. Off Grid

When the inverter has only batteries or photovoltaic cells, the inverter will be Off Grid mode after normal operation. When the Grid is connected, the inverter will automatically switch to grid connection, and automatically enter the "Self Use" or "Peak shaving" mode according to the user's settings.

When the Grid is disconnected, the inverter will automatically switch to Off Grid state.

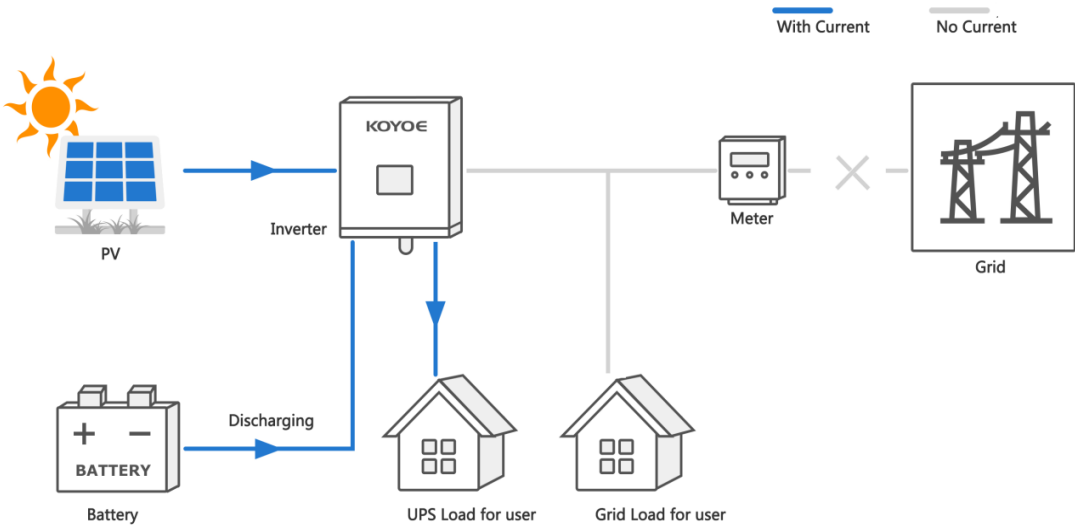

Attention:

- The utility grid must be an off-grid application of the TN system;
- This mode is not suitable for the supply of life-sustaining medical equipment, which may cause personal injury in case of power failure;
- When the inverter is only connected to photovoltaic and power grid, the inverter can also be connected to the grid.

4. Working States

4.1 Waiting

When the inverter is only connected to the power grid or photovoltaic, the inverter enters the standby state. At this time, the LCD displays "waiting", and the inverter will always detect the current working state. When the conditions are met, the inverter will automatically return to normal.

4.2 Checking

After the inverter is powered on or restarted from a recoverable fault, the check self-test will be carried out. At this time, the LCD displays "checking 60s". If there is a fault or warning in the self-test, the inverter will prompt.

4.3 Normal

After the inverter self inspection is successful, the inverter will enter the normal working state. At this time, the LCD operation light is always on, and the user can view relevant information through the LCD.

4.4 Fault

When the inverter fails, the inverter will automatically stop output and enter the fault mode, and the fault information will be displayed on the LCD. Before entering the fault mode, the inverter will automatically save relevant information. If the fault is a recoverable fault, the inverter will automatically resume operation. In case of unrecoverable fault, the inverter will stop in the fault mode until relevant technicians handle the fault.

Please refer to the following figure for the wiring diagram of neutral point continuity

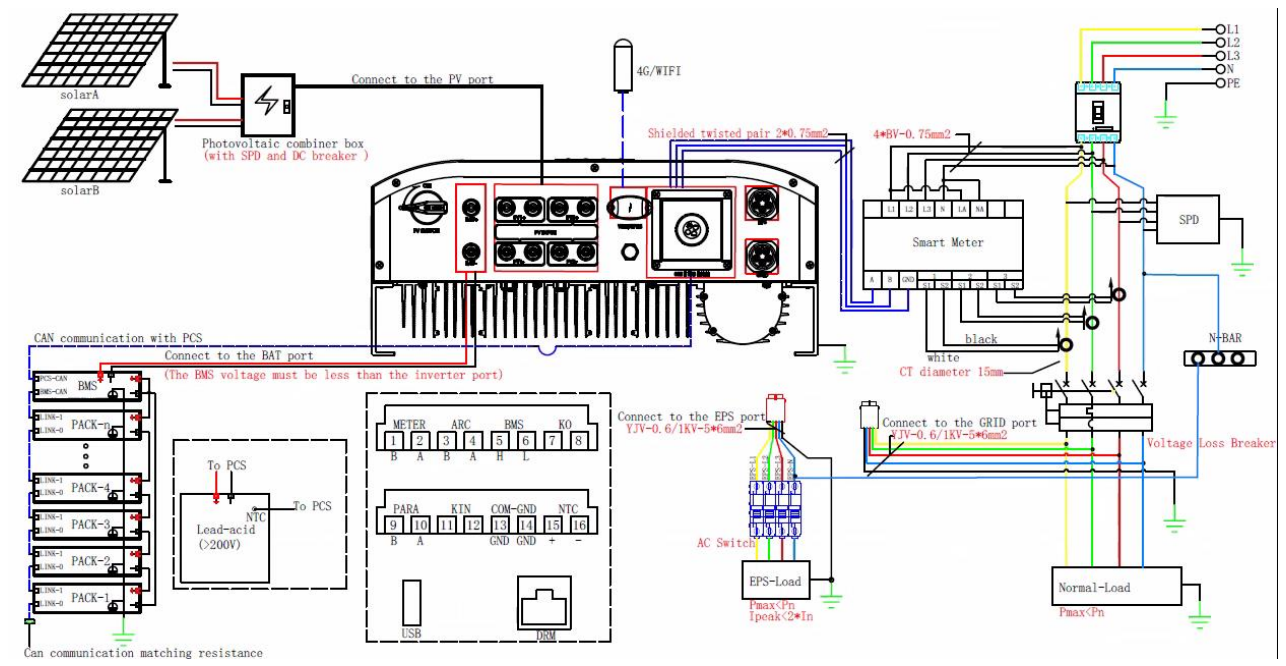

 **Our inverter does not support multi-machine parallel mode temporarily**

 **Warning!**
-In case of inverter failure, it must be repaired by professionals
- The error codes displayed on the LCD can be viewed in the appendix

4.5 Upgrade

Regardless of the working mode of the inverter, when the system meets the conditions for updating software, the inverter will enter the upgrade state and rewrite the firmware. Users can download the latest upgrade operation guide from the official website of KOYOE Energy.

5. Function Description

5.1 Safety Function

The protective functions are integrated in the inverter, including SPD protection, short circuit protection, grounding insulation resistance surveillance, residual current protection, anti-islanding protection, DC overvoltage / over-current protection, etc.

	<p>Warning!</p> <p>-There is an integrated leakage current detection unit inside the inverter. When the inverter detects the leakage current greater than the allowable value, it will be disconnected from the grid quickly</p> <p>-If RCD(Leakage Current Protector) or Leakage Current Switch is installed externally, the operating current must be $\geq 300\text{mA}$.</p>
--	--

Users can set the working mode of the inverter through LCD. In general, the factory setting is the default parameter of the corresponding country.

Users can set safety rules according to the actual environment they are using. The operation of setting safety rules is shown in the figure5-1(Australia_A):

- Step 1: Press the "Enter" button in the main interface to ENTER the interface below, select the "Settings" option through the "Up" button and the "Down" button, and then press the "Enter" button to ENTER the next level menu.
- Step 2: After entering the following menu, select the option of "Safety Parameters" through the "Up" and "Down" buttons, and then press the "Enter" button to Enter the next menu.
- Step 3: After entering the following menu, enter the password through the "Up" button and "Down" button to enter the next menu. Safety information is an important parameter, in order to ensure the safety of users and set, password can be obtained by consulting customer service.
- Step 4: After the password is entered correctly, the user can Enter the following menu. The user can select the safety rules that need to be set through the "up" and "down" keys, and then press the "ENTER" button to confirm. After successful setting, "OK" will be prompted, and then press the "Esc" key to return to the main screen.

The figure5-2 correspond to Australia respectively_ A、Australia_ B、Australia_ C、Newzealand

Equipment information mainly displays: module name, product serial number, currently selected safety regulation type and software version number

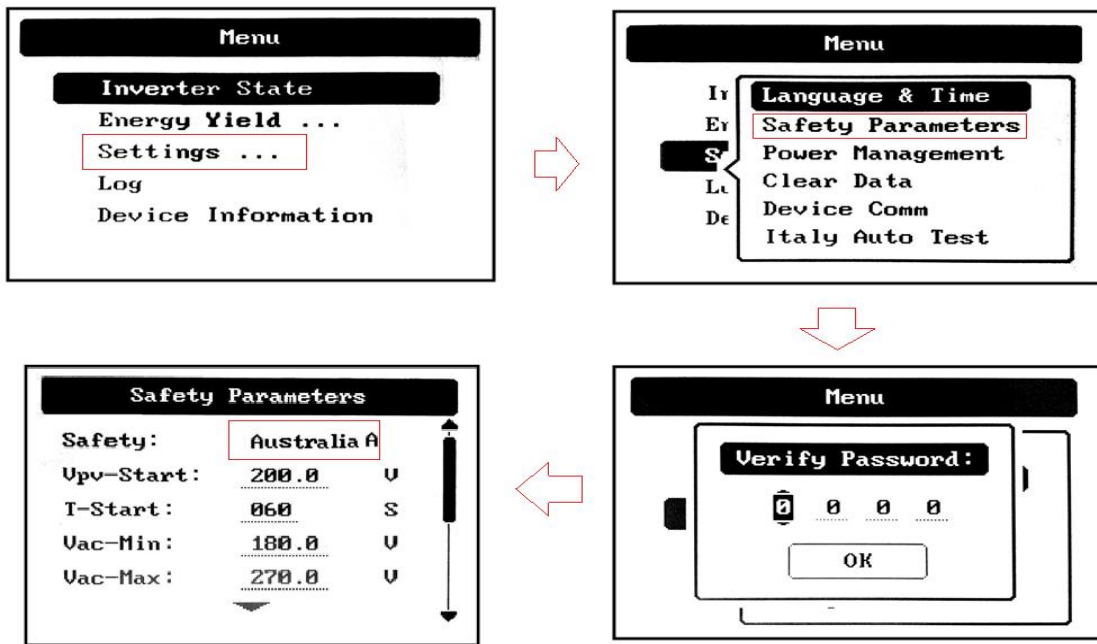
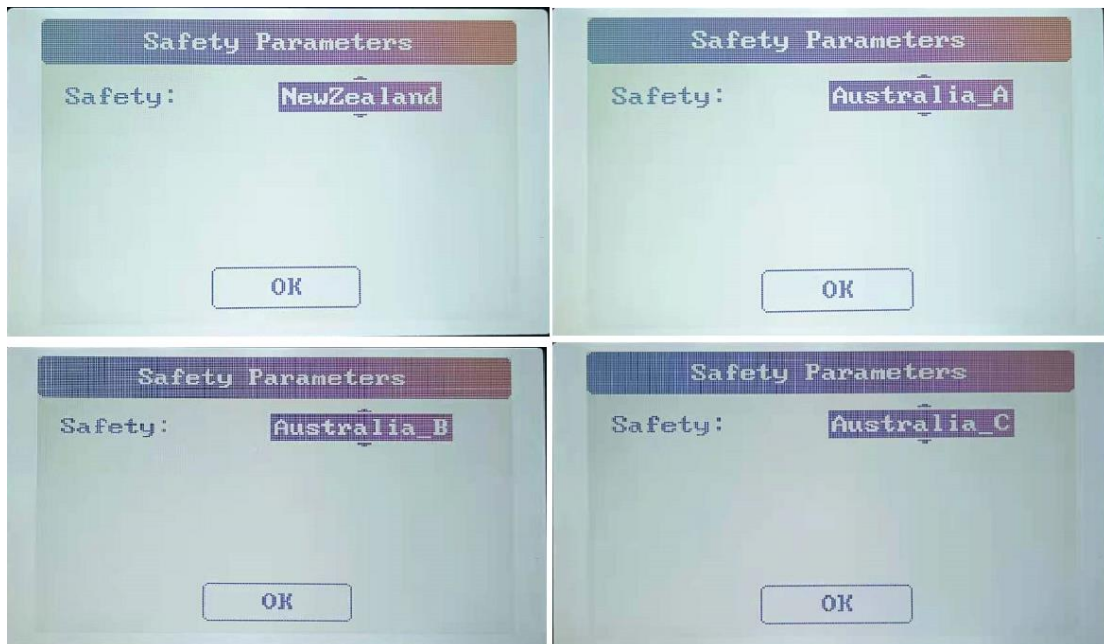

Figure5-1 Safety Setting



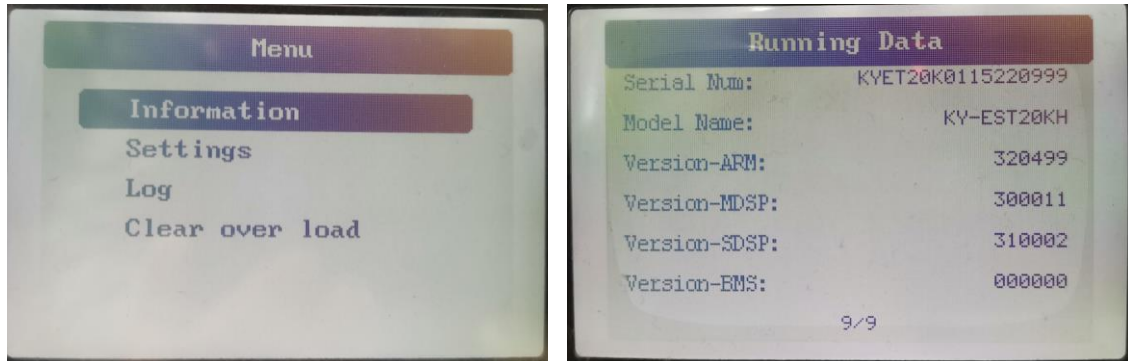

Figure 5-2

Once power quality and grid Settings are selected during debugging, they should be locked, non-editable (unless password is used), and used only for viewing. Passwords are not always available. You are advised to obtain passwords from the manufacturer and the importer or exporter as required for independent maintenance

You can perform the following steps to view the configured country code/firmware version and power quality response mode. (Do not need access permission to view)

Please refer to the following steps:

Step 1: Press "OK" on the main interface to enter the next interface, then display "Information" under the "Menu" Menu, and then press "OK" to enter the next Menu.

Step 2: Enter the menu of "Running Data" and click "Up" and "Down" to view the firmware version/country code and power quality response mode after setting.

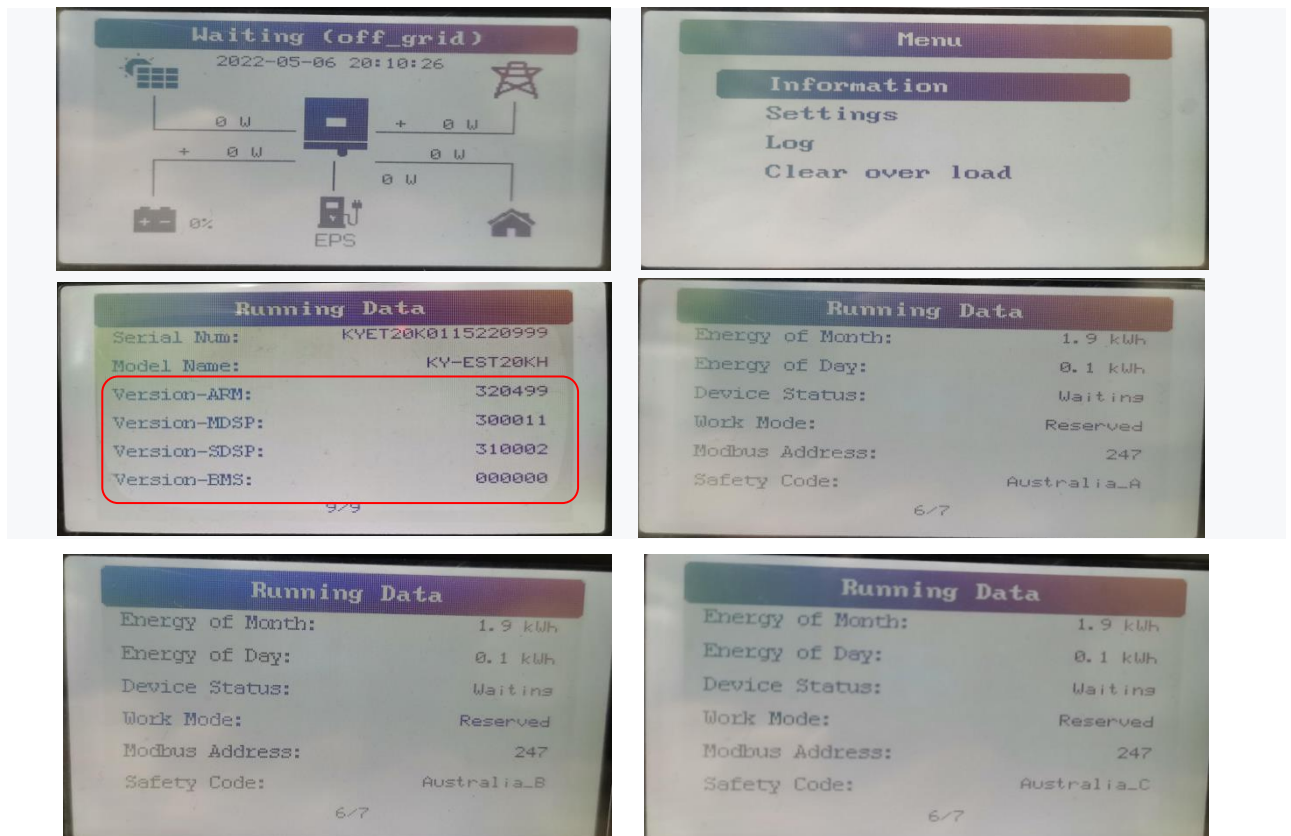

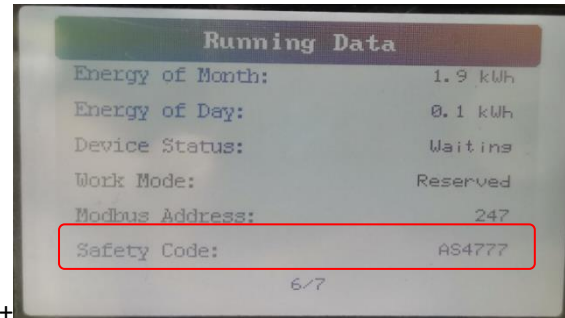
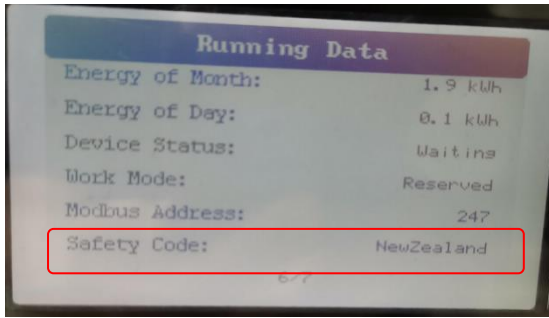

View the power quality response mode

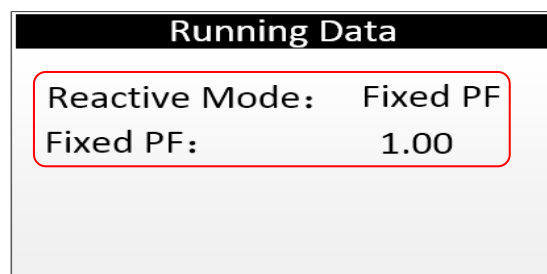
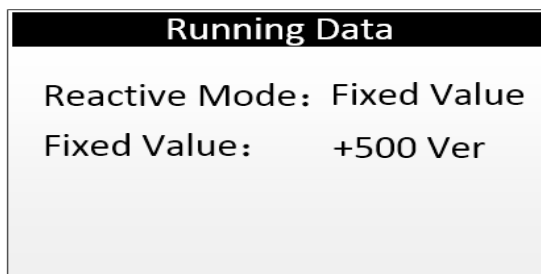
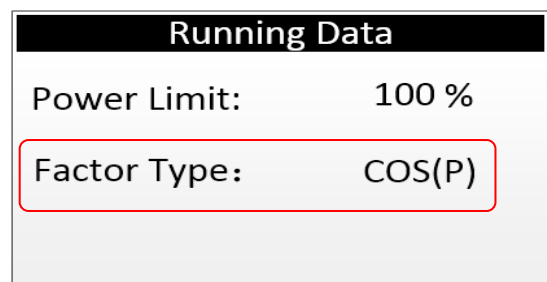
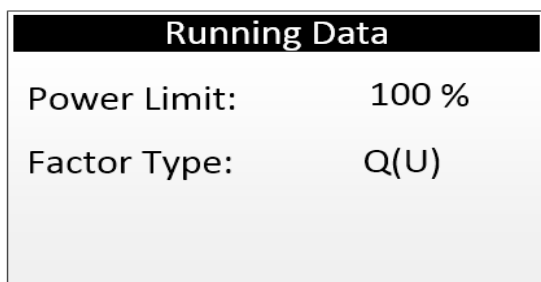
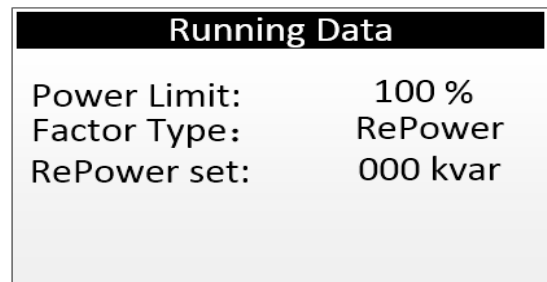
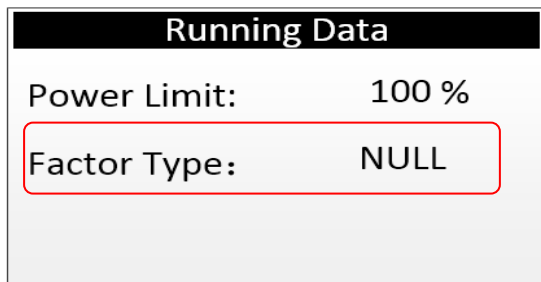
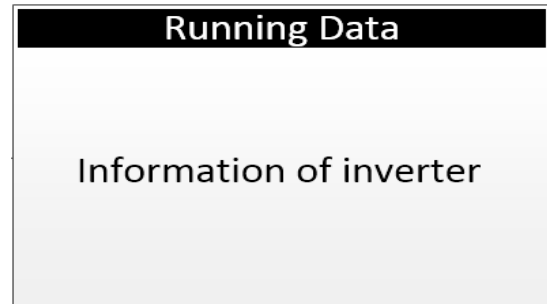

5.2 Power quality response modes

Can set the power quality mode through the following steps.

- Step 1: Press the "Enter" button in the main interface to ENTER the interface below, select the "Settings" option through the "Up" button and the "Down" button, and then press the "Enter" button to ENTER the next level menu.
- Step 2: After entering the following menu, select the option of "Power regulation setting" through the "Up" and "Down" buttons, and then press the "Enter" button to Enter the next menu.
- Step 3: After entering the following menu, enter the password through the "Up" button and "Down" button to enter the next menu. Power management information is an important parameter, in order to ensure the safety of users and set, password can be obtained by consulting customer service.
- Step 4: Enter the correct password, enter the following menu.

The user can select the power quality mode to be set by "up" and "Down"(four modes are provided,as shown in figure 5-2-2), and then press "ENTER" to confirm. After the Settings are successful, the system displays OK, and press Esc to return to the home screen,the general steps are shown in Figure 5-2-1.

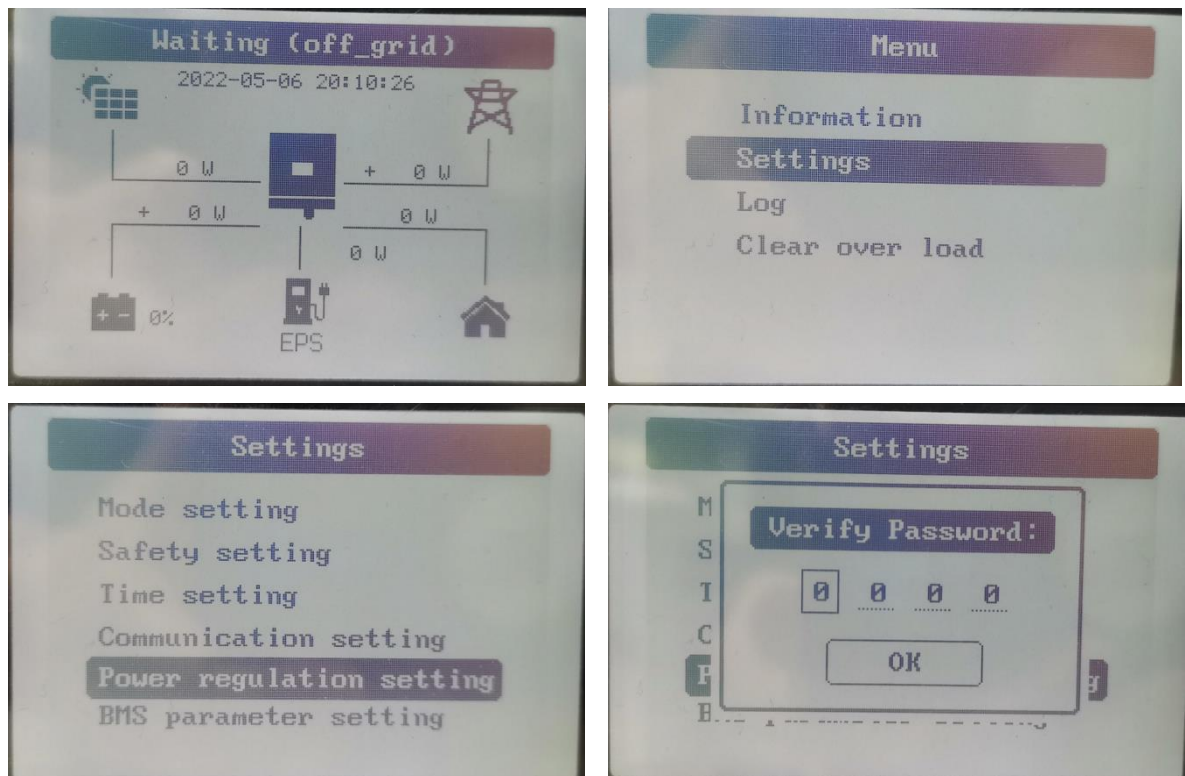

Figure 5-2-1

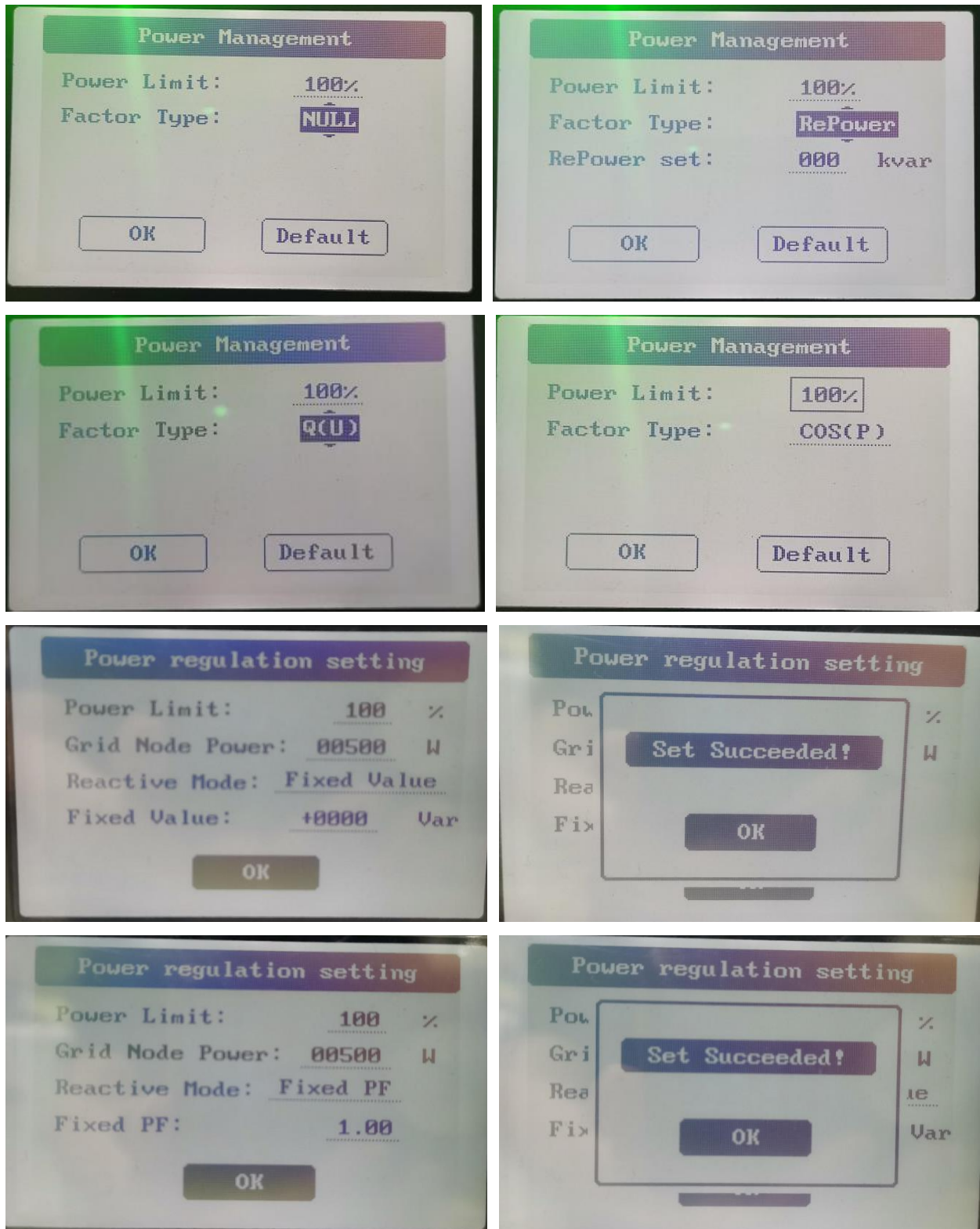

Figure 5-2-2

5.3 Energy Conversion and Management

The inverter converts the DC power from the PV strings or the battery to the AC power, which conforms to the grid requirements. It also transmits the DC power from the PV panel to the battery. The inverter is integrated with a bidirectional converter, which can charge or discharge the battery. Two string MPP trackers can be utilized to maximize the power from PV strings with different orientations, tilts, or module structures.

5.4 Power Derating

Power derating is a way to protect the inverter from overload or potential faults. In addition, the derating function can also be activated by the requirements of the utility grid. Situations requiring inverter power derating are:

- grid dispatching;
- over-temperature (including ambient temperature and module temperature);
- grid under-voltage;
- export power limit setting;
- power factor.

Grid Dispatching Derating

Adjust the output power according to the remote scheduling instructions and the inverter operates with the power derating.

Over-temperature Derating

A high ambient temperature or poor ventilation will lead to a power derating of the inverter.

When the internal temperature or module temperature exceeds the upper limit, the inverter will reduce the power output until the temperature drops within the permissible range.

Grid Under-voltage Derating

When the grid voltage is too low, the inverter will reduce the output power to make sure that the output current is within the permissible range. The following figure shows the under-voltage derating curve.

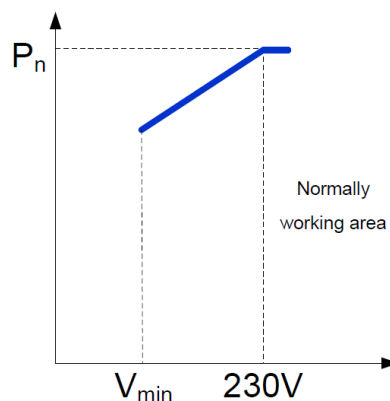

Power Factor Derating

When the power factor $PF < 1.0$, the inverter will reduce the output power within a specified range. The following figure shows the power factor derating curve.

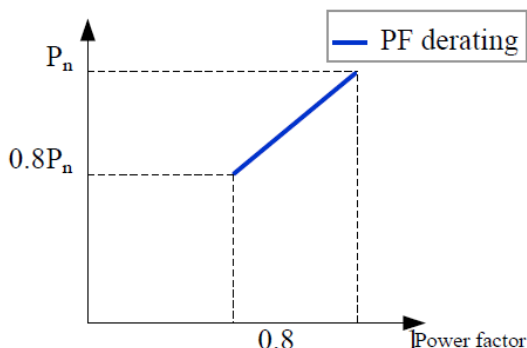

5.5 External Demand Response

The inverter provides a terminal block (RJ45) for connecting to a demand response enabling device (DRED). The DRED is demand response modes (DRMs). The Dred Demand Response Model (DRMS) is applicable in Australia. The inverter detects and initiates a response to all supported demand response commands within 2s.

The following table lists the DRMs supported by the inverter.

Mode	Explanation
DRM0	The inverter is in the state of "Disconnect Output".
DRM1	The import power from the grid is 0.
DRM2	The import power from the grid is no more than 50% of the rated power.
DRM3	The import power from the grid is no more than 75% of the rated power.
DRM4	The import power from the grid is 100% of the rated power, but subject to the constraints from other active DRMs.
DRM5	The export power to the grid is 0.
DRM6	The export power to the grid is no more than 50 % of the rated power.
DRM7	The export power to the grid is no more than 75 % of the rated power.
DRM8	The export power to the grid is 100 % of the rated power, but subject to the constraints from other active DRMs.

The DRED may assert more than one DRM at a time. The following shows the priority order in response to multiple DRMs.

Multiple Modes

DRM1...DRM4

DRM5...DRM8

Priority Order

DRM1 > DRM2 > DRM3 > DRM4

DRM5 > DRM6 > DRM7 > DRM8

DRM Connects to the DRM Port of the inverter

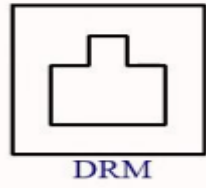

RJ45 SOCKET PIN ASSIGNMENT	
PIN	Assignment for inverters capable of both charging and discharging
1	DRM1/5
2	DRM2/6
3	DRM3/7
4	DRM4/8
5	REF GEN/0
6	COM LOAD/0
7	NA
8	NA

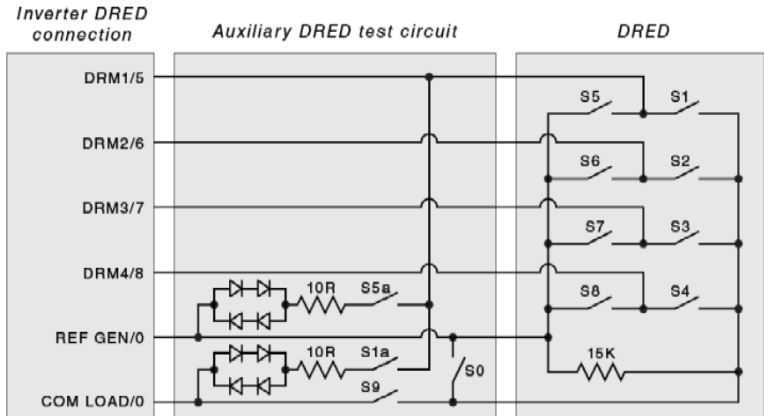

6. Unpacking and Storing

6.1. Unpacking and Inspecting

The inverter is thoroughly tested and strictly inspected before delivery. Damage may still occur during shipping. Therefore, the first thing you should do after receiving the device is to conduct a thorough inspection.

1. Check the packaging for any visible damage.
2. Check the delivery contents for completeness according to the packaging list.
3. Check the inner contents for any visible damage.

Contact KOYOE or the supplier in case there is any damage or incompleteness.

Do not dispose of the original packing case. It is recommended to store the inverter in it.

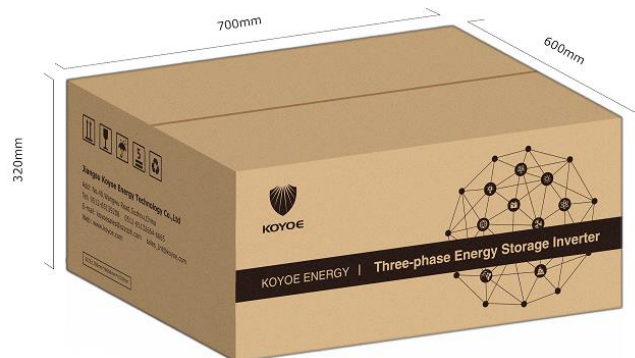

Fig. 6-1 Single Inverter in Original Packing Carton (unit: mm)

6.2. Packing List

On receiving the inverter, please check to make sure all the components as below are not missing or broken. Please subject to the real object. WiFi or 4G modules shall be purchased separately by the user.

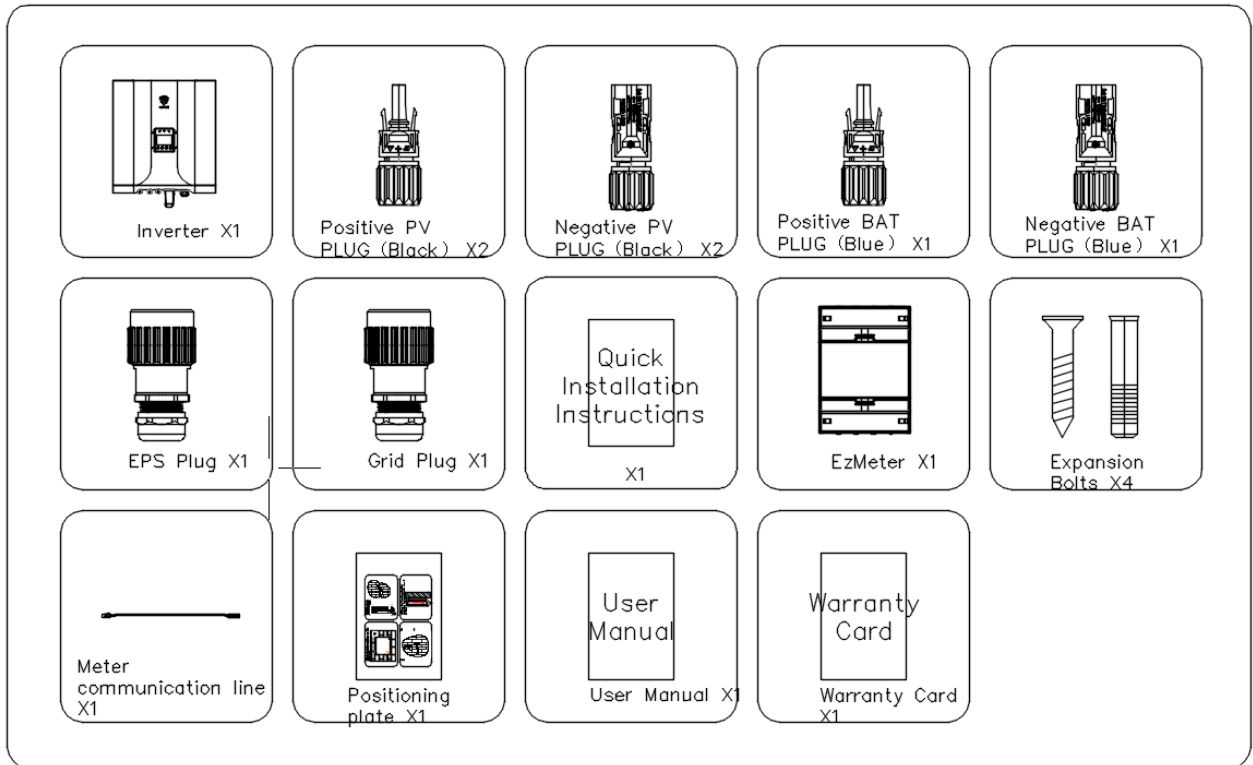

Fig. 6-2 Packing List (KY-EST06-10KH)

Number	Description	Pcs
1	Inverter	1
2	Positive PV Plug	2
3	Negative PV Plug	2
4	Positive BAT Plug	1
5	Negative BAT Plug	1
6	EPS Plug(red)	1
7	Grid Plug(black)	1
8	WiFi/4G Module(be purchased separately by the user)	1
9	Meter(4-port three-phase)	1
10	Expansion Bolts	4
11	Meter communication line	1
12	Position plate	1
13	User manual	1
14	Warranty Card	1
15	Quick installations instructions	1

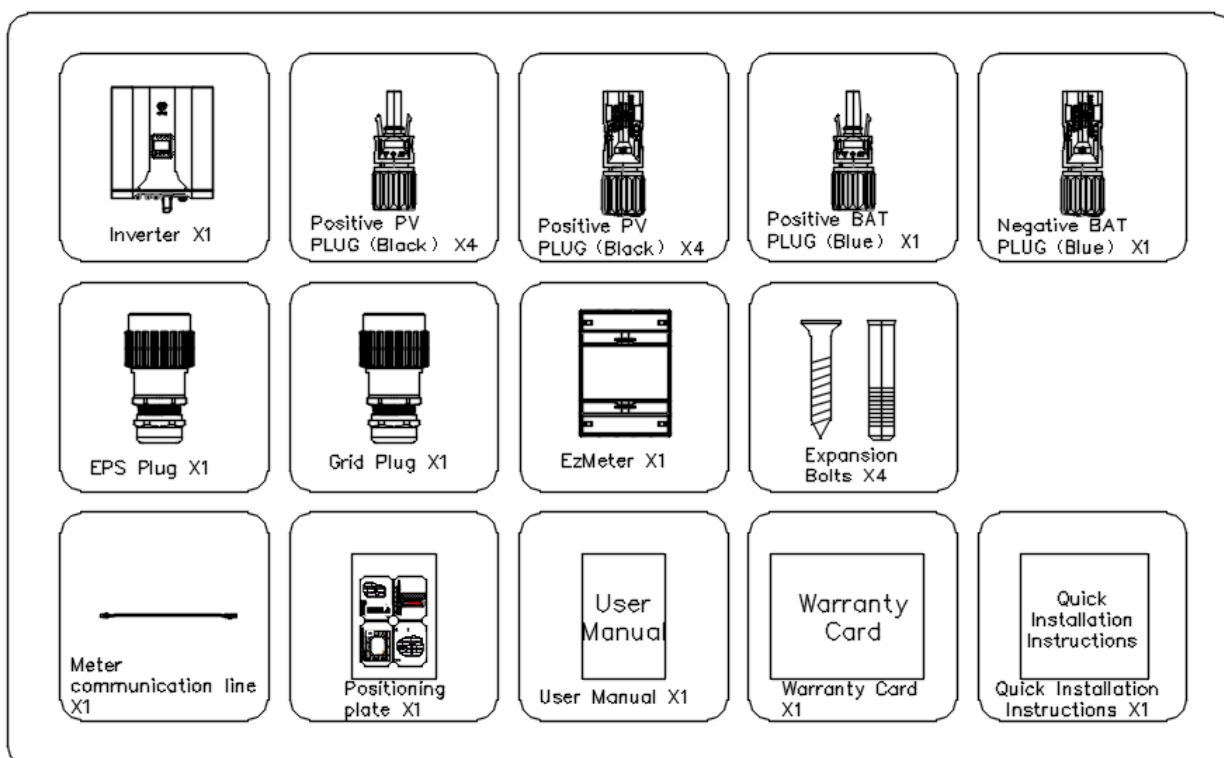

Fig. 6-2 Packing List (KY-EST12-20KH)

Number	Description	Pcs
1	Inverter	1
2	Positive PV Plug	4
3	Negative PV Plug	4
4	Positive BAT Plug	1
5	Negative BAT Plug	1
6	EPS Plug(red)	1
7	Grid Plug(black)	1
8	Meter(4-port three-phase)	1
9	Expansion Bolts	4
10	Meter communication line	1
11	Position plate	1
12	User manual	1
13	Warranty Card	1
14	Quick installations instructions	1

6.3. Inverter Storage

Proper storage is required if the inverter is not installed immediately.

-Store the inverter in the original packing case with the desiccant inside.

-The storage temperature should be always between -30°C and +85°C, and the storage relative humidity should be always between 0 and 100 %.

- In case of stacking storage, the number of stacking layers should never exceed the limit marked on the outer side of the packing case (6 layers).
- The packaging must be upright.
- If the inverter has been stored more than a year, the qualified personnel should thoroughly check and test it before using.

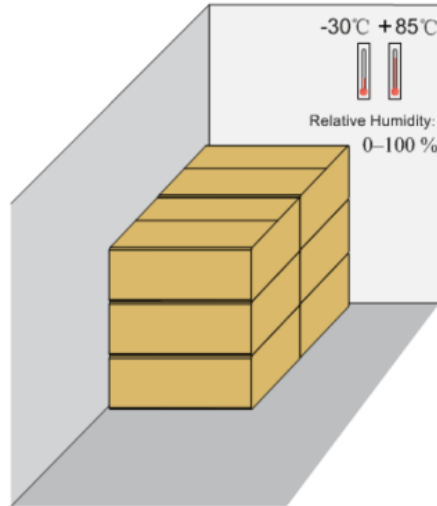

Fig. 6-3 Example of Inverter Storage

7. Mechanical Mounting

7.1. Safety during Mounting



Warning!

**Make sure there is no electrical connection before installation.
In order to avoid electric shock or other injury, be sure there is no electricity or plumbing installations before drilling holes.**



Warning!

**Wear gloves to avoid scratches when mounting the inverter.
The inverter must be installed by professionals.**



Warning!

The following improper practices may cause personal injury.

- When moving and positioning the inverter, it must be operated according to the instructions.
- System performance may deteriorate due to poor ventilation.
- To ensure safety, do not open the top cover.

7.2. Mounting Location

Choose an optimal installation location to facilitate safe operation and maximize the performance and long life of the inverter.

IP65 inverters can be installed indoors and outdoors.

Install the inverter in a place that facilitates electrical connection, operation and maintenance.

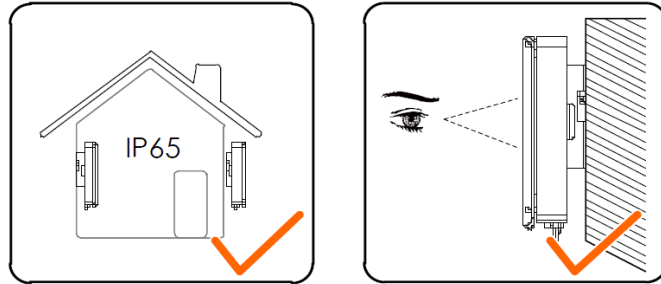

7.2.1. Installation Environment Requirement

The installation environment of the inverter must meet the following requirements:

- The installation environment must be away from flammable and explosive dangerous goods.
- Inverters must be installed in an environment out of reach of children.
- Ambient temperature ($-25^{\circ}\text{C} \sim +60^{\circ}\text{C}$) and relative humidity (0% ~ 100% without condensation).
- Direct exposure of the inverter to sunlight, rain and snow is prohibited.
- The inverter should be well ventilated to ensure air flow to the radiator.
- Do not install inverters in living areas, otherwise the inverter will produce noise during operation, affecting daily life.

7.2.2. Installation Carrier Requirement

The installation carrier should meet the following requirements:



Made of non-flammable materials



Max. load bearing capacity ≥ 4 times of inverter weight

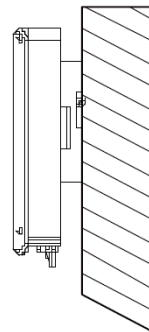

7.2.3. Installation Angle Requirement

Never install the inverter horizontally, or with a forward tilt or with a backward tilt or even with upside down. The horizontal installation can result in damage to the inverter.

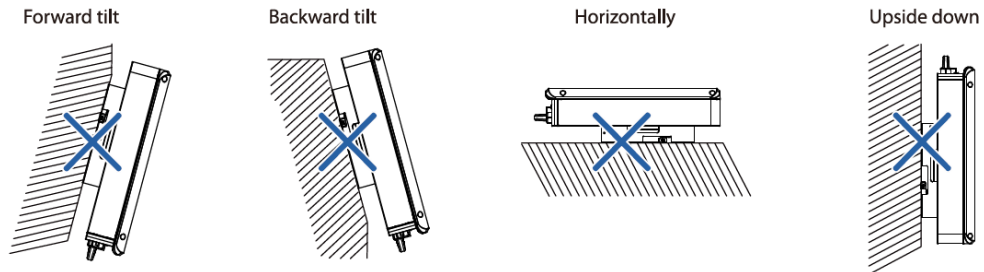

7.2.4 Installation Clearance Requirements

Reserve enough clearance around the inverter to ensure sufficient space for heat dissipation. Clearance requirement:

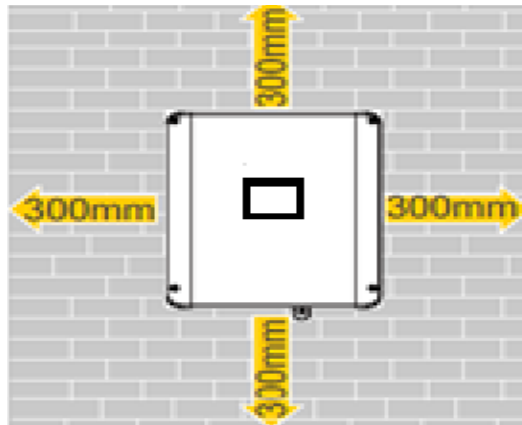

7.2.5 Mounting the Inverter

Remember that this inverter is heavy! Please be careful when lifting out from the package.

- The inverter is suitable for mounting on concrete or other non-combustible surface only.
- The maximum load bearing of the carrier must be greater than or equal to four times the weight of the inverter.

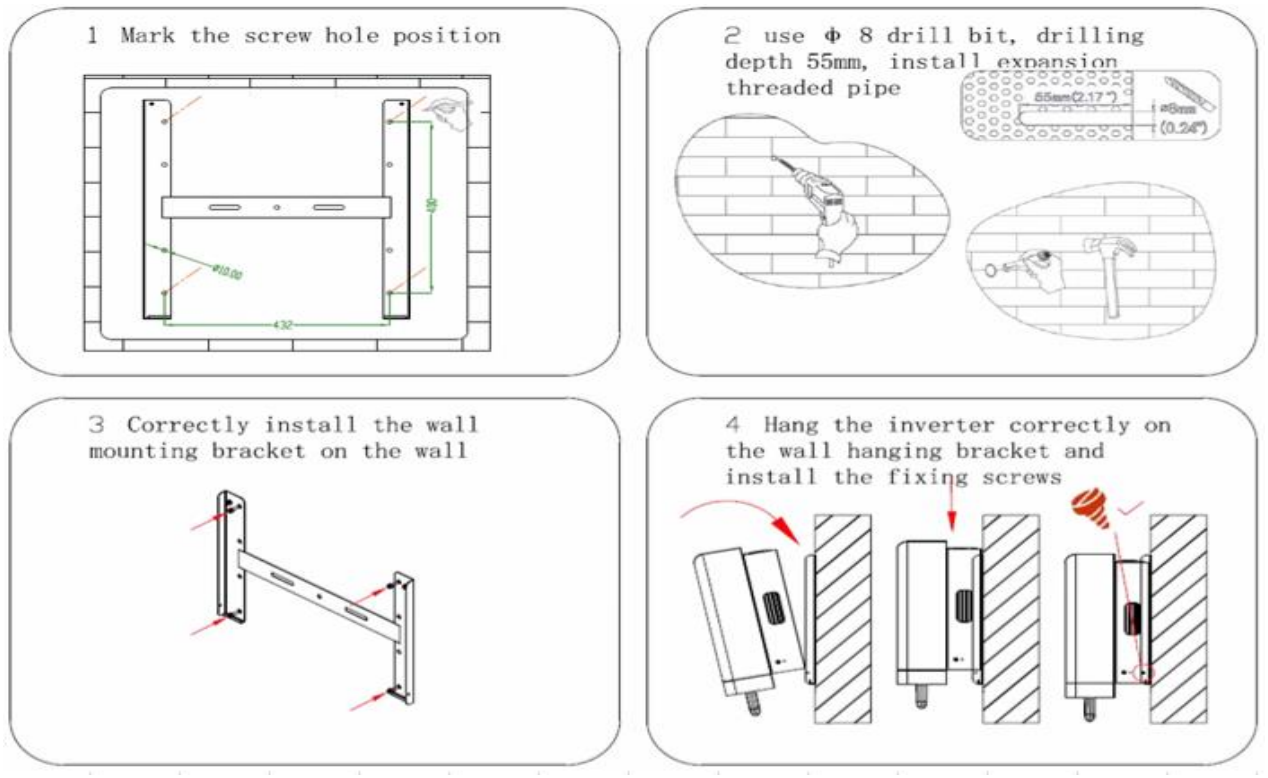

Step1: Mark the screw hole position;

Step2: use ϕ 8 drill bit, drilling depth 55mm, install expansion threaded pipe;

Step3: Correctly install the wall mounting bracket on the wall;

Step4: Hang the inverter correctly on the wall hanging bracket and install the fixing screws.

8. ELECTRICAL WIRING CONNECTION

8.1. Safety Instruction

Before any electrical connection, remember that this inverter is multi-power supplied. Electrical connections must be made by a professional and personal protective equipment must be worn.

Warning!

Inverter has lethal high voltage inside, please pay attention to safety when operating.

- PV panels can produce lethal high voltage in sunlight. Do not touch PV output cables or interfaces.
- Confirmed that the DC and AC circuit breakers have been disconnected and that they are not inadvertently reconnected before starting electrical connections.
- Before connecting cables, make sure all cables are free of voltage or current.

Warning!



Any improper operations during cable connection can cause device damage or personal injury.

Only qualified personnel can perform cable connection.

All cables must be undamaged, firmly attached, properly insulated and adequately dimensioned.

Warning!



Comply with the safety instructions related to the PV strings and the regulations related to the utility grid.

All electrical connections must be in accordance with local and national standards.

Only with the permission of the utility grid, the inverter can be connected to the utility grid.

8.2. Terminal Description

All electrical terminals are located at bottom of the inverter. The diagram below shows the external interface of the inverter(KY-EST20KH):

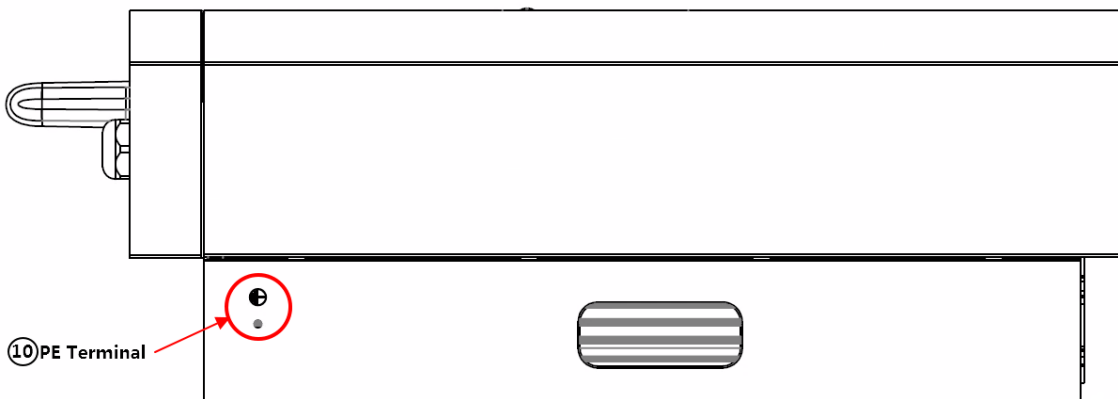
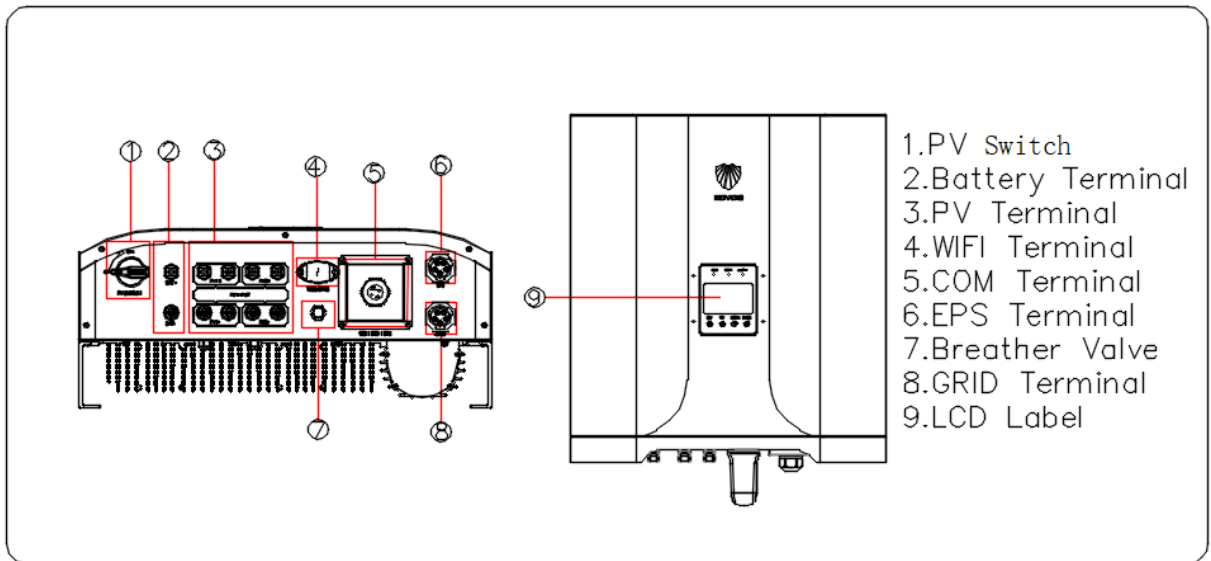

No.	Name	Description
1	PV Switch	DC Switch for PV input
2	Battery Terminal	Connectors for the battery power cables
3	PV Terminal	Positive and negative DC input connectors
4	WIFI Terminal	Connector for 4G/WIFI module
5	COM Terminal	Connector for Smart Energy Meter,RS485,BMS/CAN,DRM/DI and DO
6	EPS Terminal	AC terminal reserved for Backup loads
7	Breather Valve	Ensure the same air pressure inside and outside the inverter
8	GRID Terminal	AC terminal for connection to the utility grid
9	LCD Label	LCD and Keys for inverter
10	PE Terminal	Connect to PE for addition grounding

* The image shown here is for reference only. The actual product received may differ.

The COM terminals of the inverter are used to achieve a specific function, and the schematic diagram of their interface is shown below:

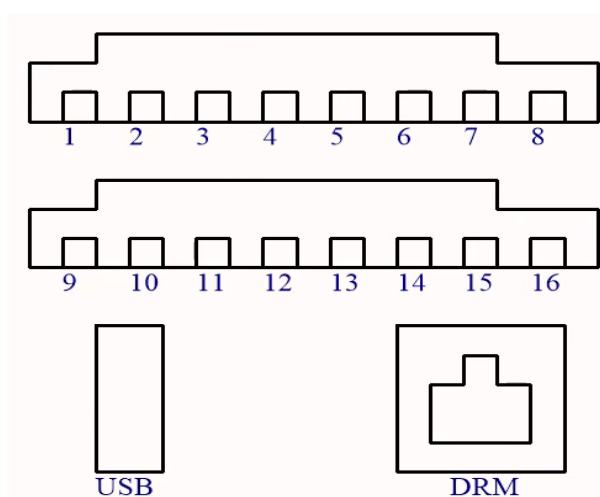

No.	Name	Description
1	Meter-485-B	RS485-B for Smart Energy Meter
2	Meter-485-A	RS485-A for Smart Energy Meter
3	ARC-485-B	Reserved port
4	ARC-485-A	Reserved port
5	BMS-CAN-H	Communication with Li-ion battery, CAN-H bus
6	BMS-CAN-L	Communication with Li-ion battery, CAN-L bus
7	KO-	Reserved port
8	KO+	Reserved port
9	PARA-485-B	Reserved port
10	PARA-485-A	Reserved port
11	KIN+	Reserved port
12	KIN-	Reserved port
13	GND	GND for external communication
14	GND	GND for external communication
15	NTC-	Connect to external NTC for lead-acid battery
16	NTC+	

8.3. Electrical Connection Overview

The inverter integrates the functions of energy storage and photovoltaic grid-connection. The system application figure is shown below :

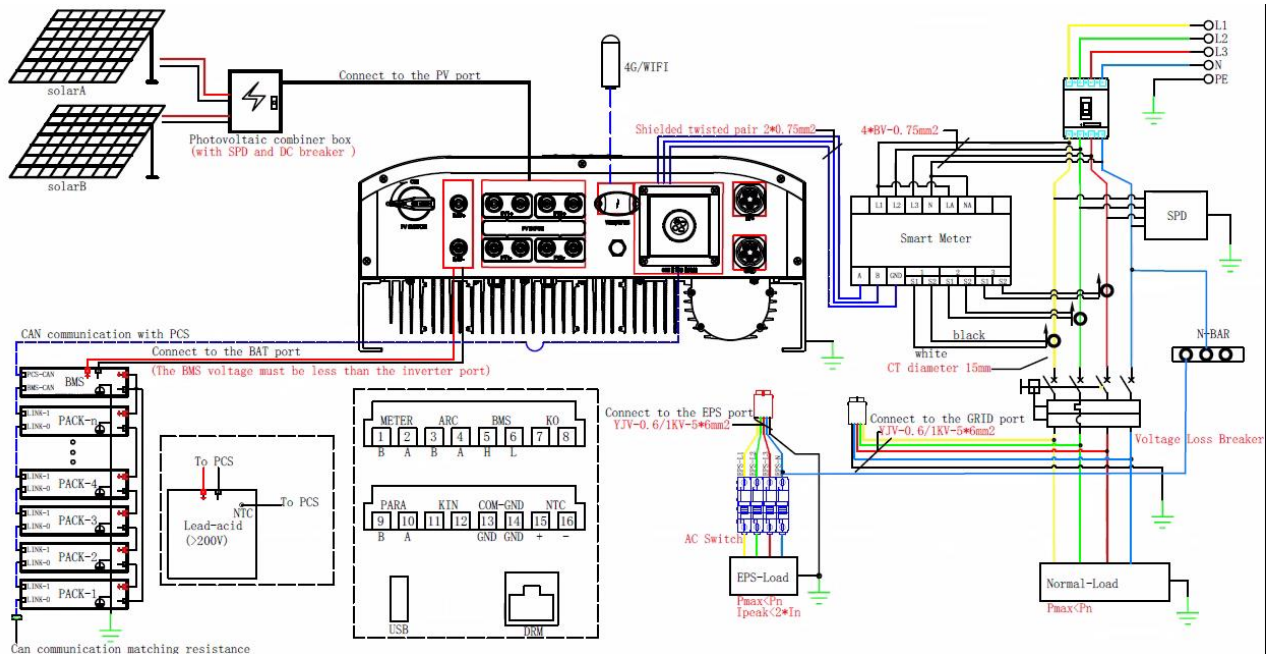

If the user requires that the load of EPS cannot be powered off, a dual power switch needs to be added, please connect it as shown in the figure below :

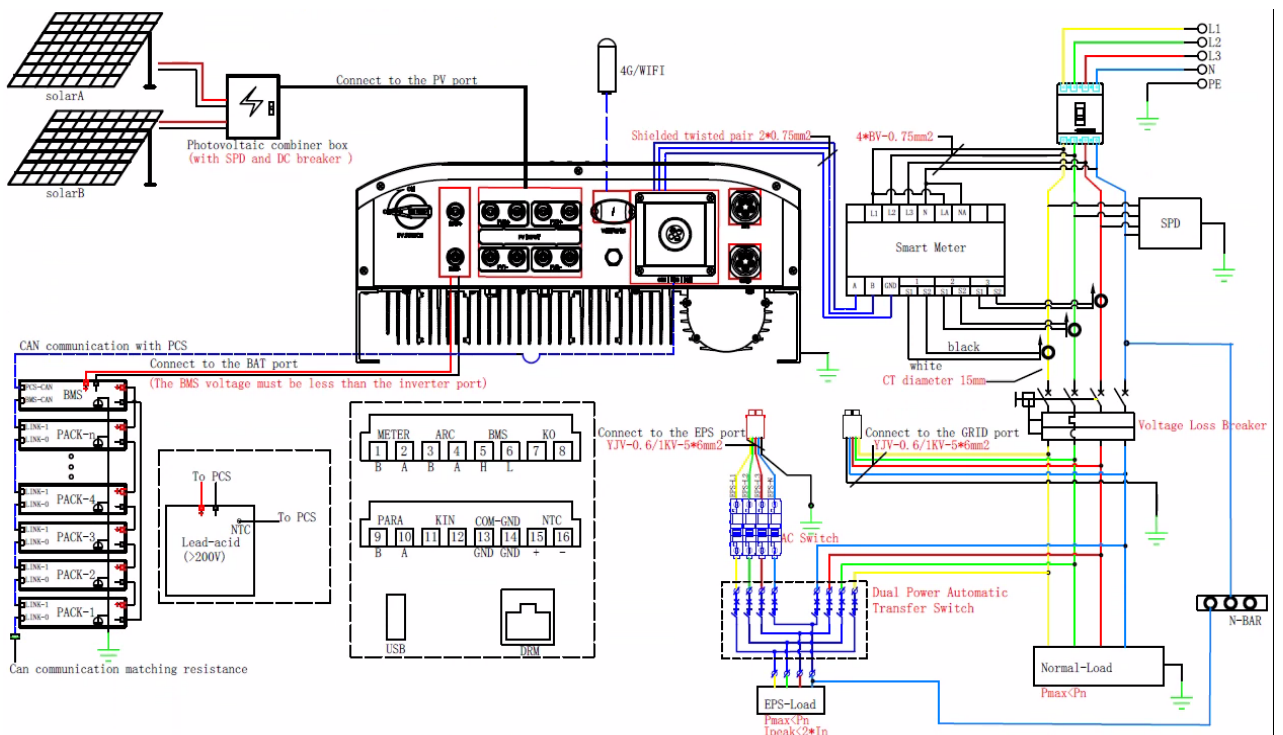

Note:

- 1) The photovoltaic input must be externally connected with SPD and DC switch;
- 2) When lead-acid battery is used, it is recommended to install battery temperature detector;
- 3) The EPS output must be connected with AC switch, and the off grid output line shall not be directly connected to Grid;
- 4) The grid connection must be connected with circuit breaker, SPD and voltage loss trip circuit breaker;
- 5) The maximum diameter of CT is 15mm, and it must be installed at the front end of ordinary load and inverter. The arrow direction of CT points to the power grid;

The electrical connection should be realized as follows:

No	Cable	Type	Outer diameter (mm)	Cross section (mm ²)
1	Battery Cable	Complying with 1000V and 50A standard	12~14mm	8mm ²
2	DC cable	Outdoor multi-core copper wire cable Complying with 1,000V and 30A standard	4~6mm	4mm ²
3	AC cable*	Outdoor multi-core copper wire cable	12~14mm	6mm ²
4	Communication cable	Shielded twisted pair	5.3~7mm	2*(0.5~1.0)mm ²
		CAT 5E outdoor shielded network cable		8*0.2mm ²
5	Additional Grounding cable	Outdoor single-core copper wire cable	The same as that of the PE wire in the AC cable	

* If local regulations have other requirements for cables, set the cable specification according to the local regulations.

Backup Wiring Diagram

Neutral line of alternative supply must not be isolated or switched. (applies to wiring rules AS/NZS_3000:2012 for Australia and New Zealand)

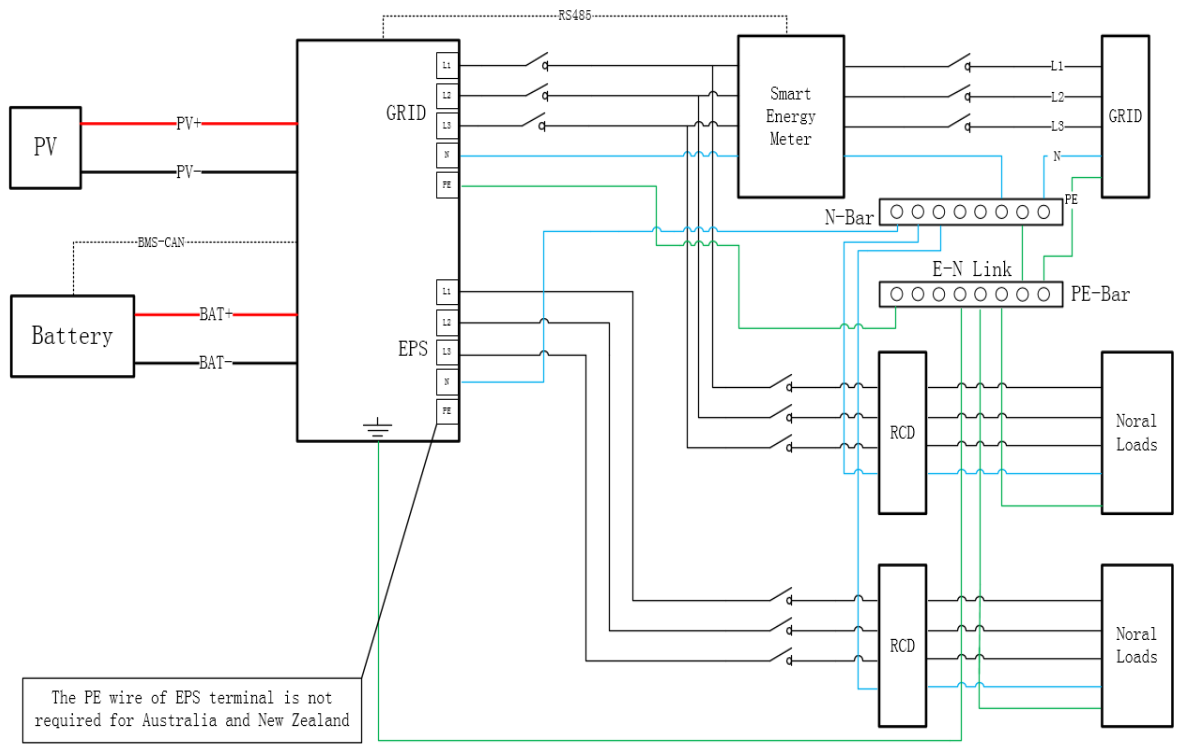

Neutral line of alternative supply must be disconnected after the grid is off (applies to other countries).

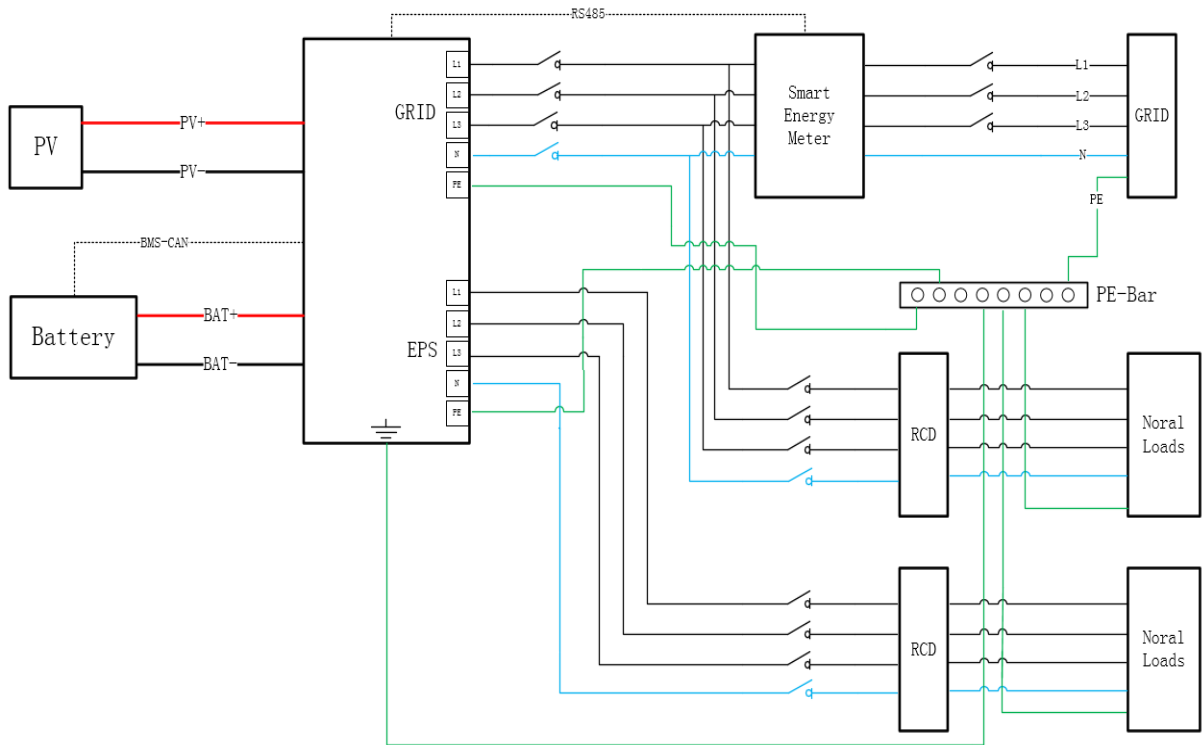

8.4. Additional Grounding Connection

Warning!



- Since the inverter is transformerless , neither the negative pole nor the positive pole of the PV string must not be grounded. Otherwise, the inverter will not operate normally.
- Connect the additional grounding terminal to the protective grounding point before AC cable connection, PV cable connection, and communication cable connection.
- The ground connection of this additional grounding terminal cannot replace the connection of the PE terminal of the AC cable. Make sure the two terminals are both grounded reliably.

a) System grounding (First PE at AC connector L, N, PE)
A single inverter system needs to ground the "PE" cable;

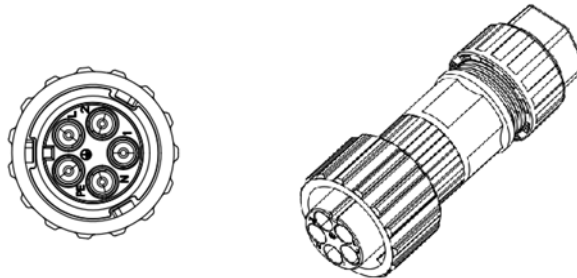

b) Protective earthing (second PE at external enclosure)
The inverter is required to add protective earthing connection port. Users can choose to connect the grounding protection line according to their needs. The grounding port is located next to the AC output port at the bottom of the inverter. The installation method is shown in Fig.

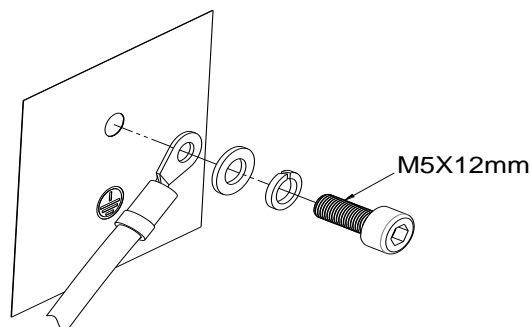

Figure connecting grounding protection wire

c) Earth fault alarm

Our inverters provide a ground fault alarm function. If there is bad grounding or ungrounding phenomenon, there are three phenomena can be observed:

1. The screen shows "isolation fault", and the red indicator lights up during startup self-check. Figure 1
2. After the inverter triggers the grounding fault, there will be an audio signal (the buzzer), and the alarm sound will continue until the fault is removed ;
3. Phone APP remote monitoring error notification; As shown in Figure 2

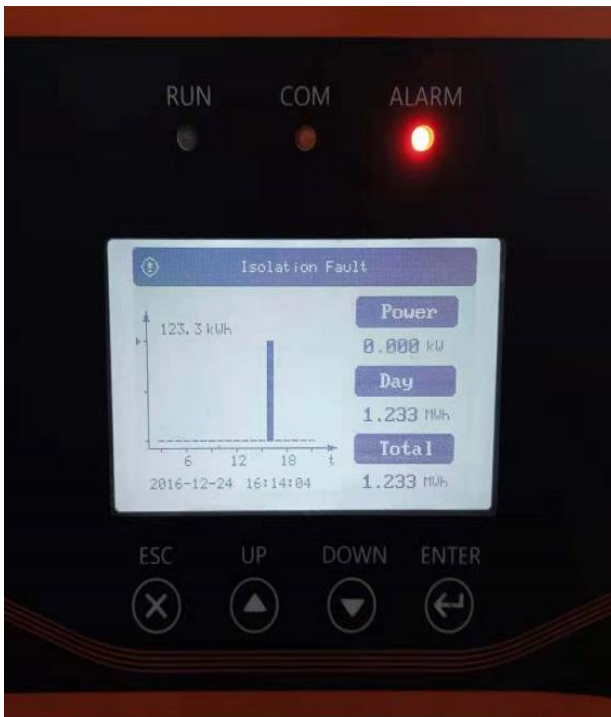

Figure 1



Figure 2



Warning!

For easy maintenance, install the inverter at eye level. Please install the product in heavy traffic areas, as ground fault alarms may be noticed by LCD, APP and Buzzer.

8.4.1 Additional Grounding Connection

All non-current carrying metal parts and device enclosures in the PV power system should be grounded, for example, brackets of PV modules and inverter enclosure.

When there is only one inverter in the system, connect the additional grounding cable to a nearby grounding point.

8.4.2 Connection Procedure

There is an additional grounding terminal located at the right side of the inverter. Additional grounding cable is prepared by customers.

Step 1 Prepare the cable and OT/DT terminal.

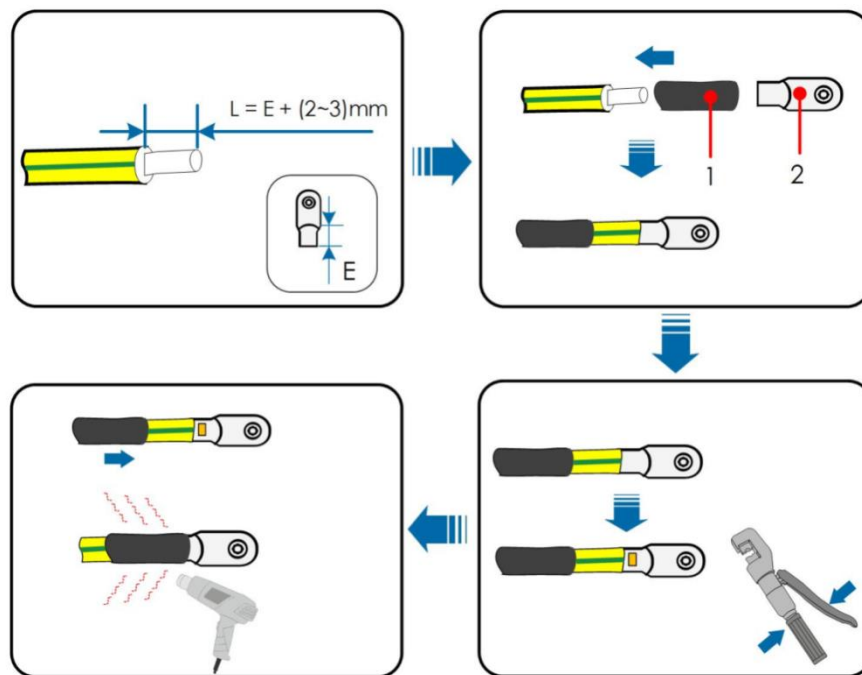

Step 2 Remove the screw on the grounding terminal and fasten the cable with a screwdriver.

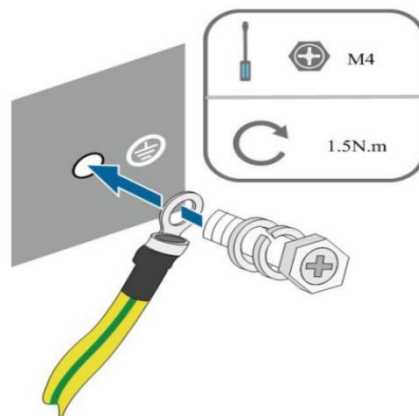

Step 3 Apply paint to the grounding terminal to ensure corrosion resistance.

8.5. PV CONNECTION



Warning!

The PV array will generate lethal high voltage once exposed to sunlight.



Warning!

Make sure the PV array is well insulated to ground before connecting it to the inverter.



Warning!

Before connecting the PV array to the inverter, ensure that the impedances between the positive terminals of the PV string and earth, and between the negative terminals of the PV string and earth are larger than 1 M Ohm.



Warning!

Risk of inverter damage! Observe the following requirements. Failure to do so will void guarantee and warranty claims.

- Make sure the maximum voltage of each string is always less than 1,000 V.
- Make sure the maximum short circuit current on the DC side is within the permissible range.

8.5. 1 PV Input Configuration

In Australia and New Zealand, ensure the DC power for any PV string never exceeds a certain level with regards to the string voltage to avoid derating:

≤ 12.5 kW if string voltage is lower than 500 V

≤ 10 kW if string voltage is between 500 V and 800 V

≤ 8 kW if string voltage is between 800 V and 1000 V

For this serial inverters, each PV input operates independently and has its own MPPT. In this way, string structures of each PV input may differ from each other, including PV module type, number of PV modules in each string, angle of tilt, and installation orientation.

8.5. 2 Assembling the PV Connector

Warning!

High voltage may be present in the inverter!

- Ensure all cables are voltage-free before performing electrical operations.
- Do not connect the AC circuit breaker before finishing electrical connection.

Before connecting PV panels/strings to inverter, please make sure to meet the requirements as below:

PV strings could not connect to earth/grounding conductor;

Use the DC plugs in the accessory box.

The mode is: VP-D4B-CHSF4(Positive poles+) ,VP-D4B-CHSM4(negative poles-)

NOTE: There will be DC plugs in accessory box, the detailed connection as below:

Step1: Prepare PV cables and DC plugs.

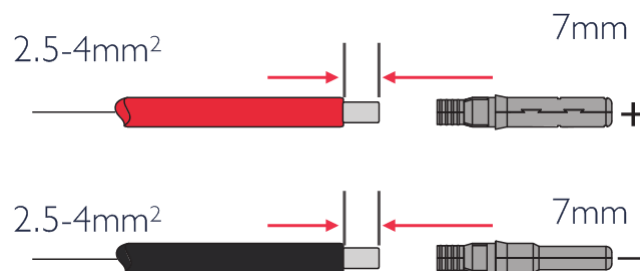

Be careful!

- Please use DC plugs and connectors in KOYOE accessory box
- PV cable should be standard, 2.5-4mm² PV cable

Step2: Connect PV cable to DC connectors

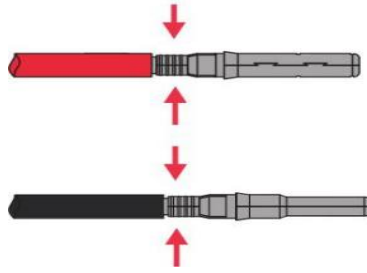

Be careful!

If the connector is damaged accidentally, please contact the after-sales service to apply for a special matching connector.

Step3: Lead the cable through cable gland. Insert the crimp contact into the insulator until it snaps into place. Gently pull the cable backward to ensure firm connection. Tighten the cable gland and the insulator (torque 2.5 N· m to 3 N· m).

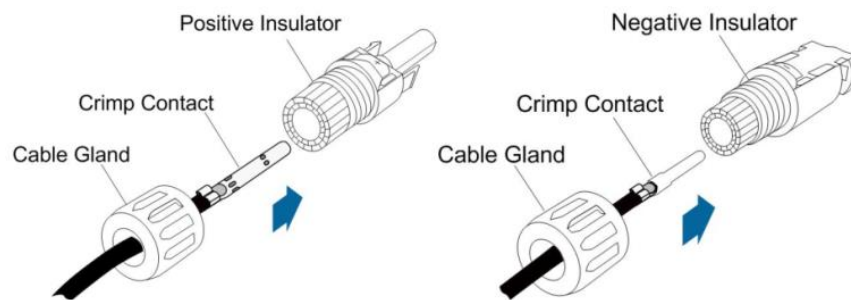

Step4: Check for polarity correctness.



Be careful!

The inverter will not function properly if any PV polarity is reversed.

8.5. 3 Installing the PV Connector

Step 1: Rotate the DC switch to “OFF” position.

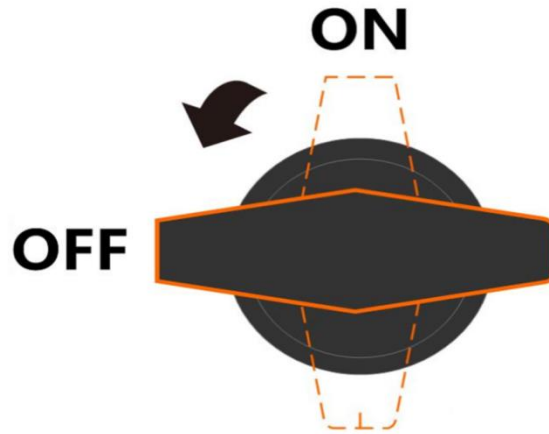

Step 2: Check the cable connection of the PV string for polarity correctness and ensure that the open circuit voltage in any case does not exceed the inverter input limit of 1,000V.

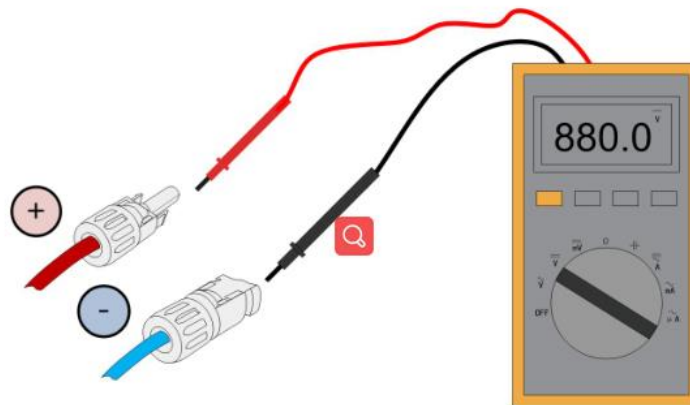

Step 3: Connect the PV connectors to corresponding terminals until there is an audible click.

1). Check the positive and negative polarity of the PV strings, and connect the PV connectors to corresponding terminals only after ensuring polarity correctness.

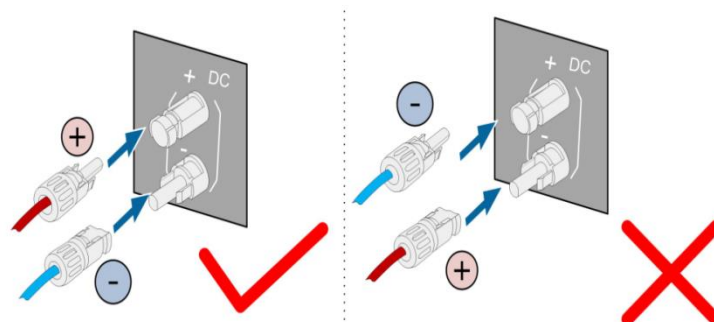

2). Arc or contactor over-temperature may occur if the PV connectors are not firmly in place, and KOYOE shall not be held liable for any damage caused due to this operation.

Step 4: Follow the foregoing steps to connect PV connectors of other PV strings.

Step 5: Seal any unused PV terminal with a terminal cap.

8.6. Battery CONNECTION



Be careful!

Only use properly insulated tools to prevent accidental electric shock or short circuits. If insulated tools are not available, use electrical tape to cover the entire exposed metal surfaces of the available tools except their tips.



Be careful!

The plug connector must be connected only by trained electricians.



Be careful!

The plug connector must be connected only by trained electricians.



Be careful!

A two-pole DC circuit breaker with over-current protection (voltage rating not less than 600 V and current rating not less than 40 A) should be installed between the inverter and the battery.

8.6.1 Connecting the Power Cable

All power cables are equipped with water-proof direct plug-in connectors, which match the battery terminals at the box of the inverter.

Connect terminals on the battery side according to the following figure. If you have any questions, please contact customer service personnel

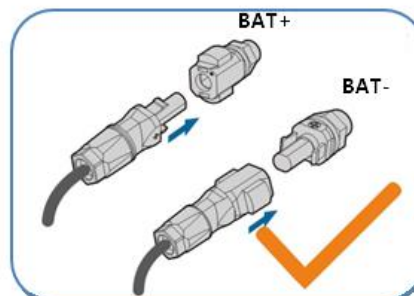

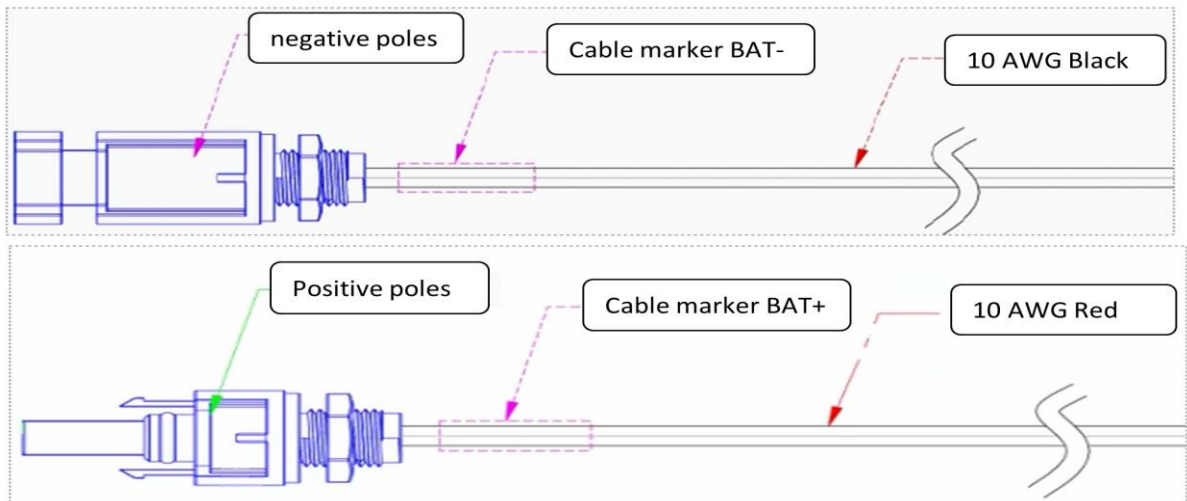

Be careful!

-Please use the battery plug and connector in the KOYOE accessory box -Battery cables should be standard 10AWG(6mm²) pv cables



Be careful!

Before connecting the connector to the inverter, make sure the positive and negative poles are correct. Make sure the positive and negative voltages are less than 800V.



Be careful!

This product does not integrate battery DC switch

8.6.2 Connecting the communication Cable

The inverter supports lead-acid batteries and lithium batteries. When connecting lead-acid batteries, please pay attention to the use environment of lead-acid batteries. When connecting the lithium battery, connect the communication line between the lithium battery and the inverter.

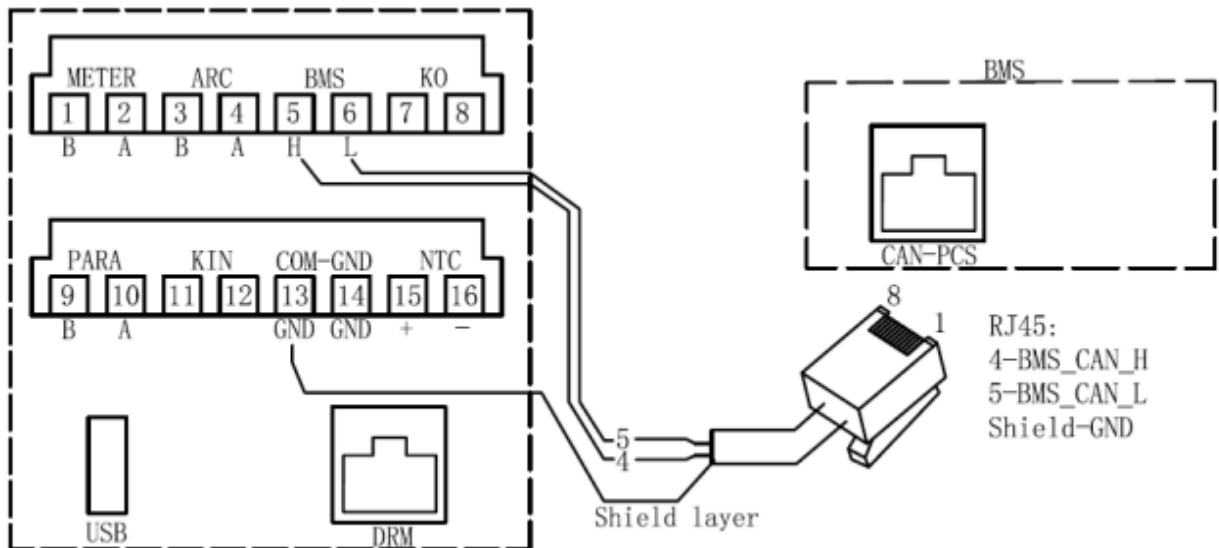

8.6.3 Connecting the NTC Cable

Lead-acid batteries are supported, The optimum operating temperature range of lead-acid batteries is 0-50°. To ensure safe operation, the inverter adjusts the power according to the temperature of NTC.

Lead acid batteries must be connected to a dedicated EXTERNAL NTC.

NTC model: NTSA0153JZ001 can be purchased. NTC detection temperature range :-25°-100°. The wiring diagram is as follows:

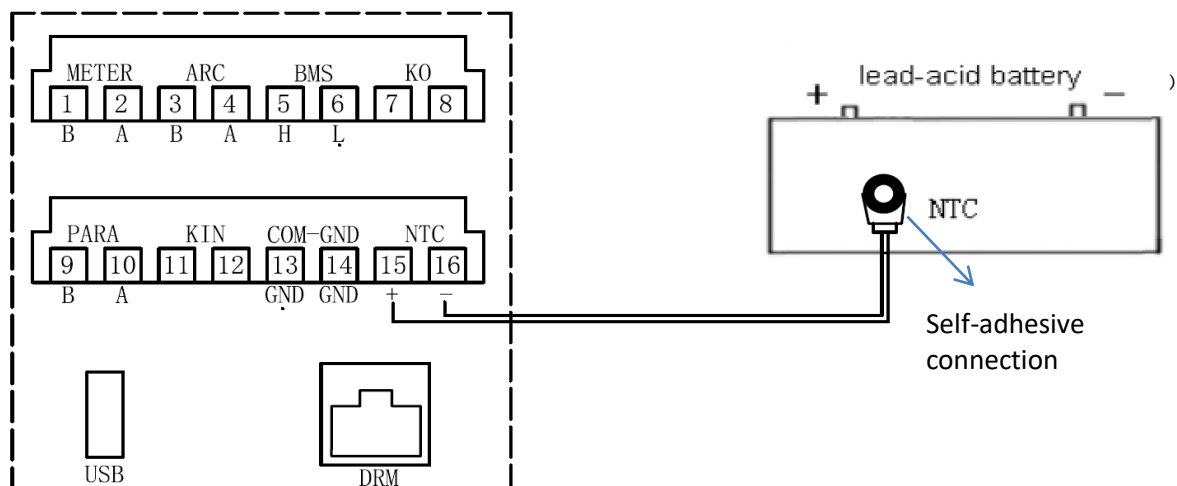

The inverter adjusts the output power when it detects the temperature of NTC, as shown in the following table:

NTC Temperature	Power
$0 <$	0%
$0-50^{\circ}$	100%
$>50^{\circ}$	50%
$>60^{\circ}$	0%



Be careful!

If ammonium lead-acid batteries are used, contact your supplier or company's professional personnel for technical installation support.

8.7. AC Cable Connection

8.7.1 Grid Side Requirements

An independent three or four-pole circuit breaker must be installed on the output side of the inverter to ensure safe disconnection from the grid.

Inverter Model	Recommended AC circuit breaker current
KY-EST12KH	63A
KY-EST15KH	63A
KY-EST17KH	63A
KY-EST20KH	63A



Be careful!

- Multiple inverters cannot share one circuit breaker.
- Never connect a load between the inverter and the circuit breaker.

Residual Current Monitoring Device

With an integrated universal current-sensitive residual current monitoring unit included, the inverter will disconnect immediately from the mains power once a fault current with a value exceeding the limit is detected.

However, if an external residual current device (RCD) is mandatory, the switch must be triggered at a residual current of 300 mA (recommended), or it can be set to other values according to local regulations. For example in Australia, the inverter can use an additional 30mA (Type A) RCD in installations.

8.7.2 Assembling the AC Connector

The GRID terminal is on the lower right of the wiring panel of the inverter. AC connection is the three-phase-four-wire grid +PE connection (L1, L2, L3, N, and PE).

Step 1: Close the fuse of the manual AC circuit breaker to prevent the circuit breaker from being opened unintentionally;

Step 2: Put the cable through the nut, sealing ring and threaded sleeve in sequence, insert the cable into the terminal according to the polarity shown on it, and tighten the screw. As shown in Figure ;

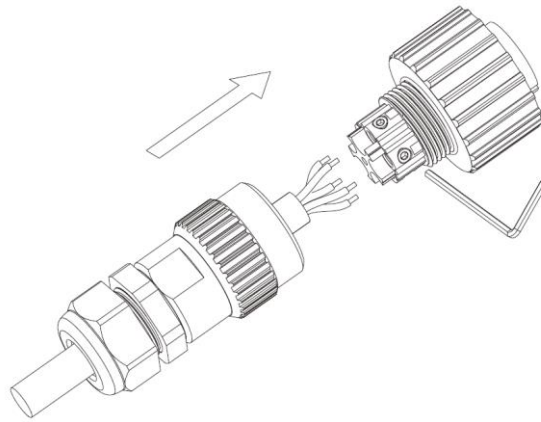

Figure loosening connector screws(the GRID terminal is black)

Step 3: Strip the cable as shown in the figure below:

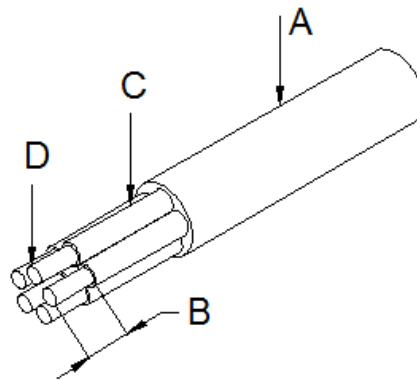

Figure loosening connector screws

Number	Description	Remarks
A	Protective layer	Cable outer diameter range : 12-14mm
B	Insulation stripping length	10mm
C	Insulating layer	-
D	Cross section area of AC cable	Maximum: 6 mm



Be careful!

The power loss on the cable should be controlled within 1% of the rated power.

Step 4: Push the threaded sleeve onto the connection terminal until both are locked. As shown in Figure:

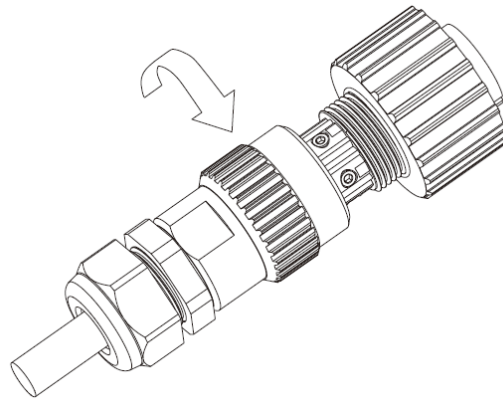

Step 5: Insert the socket into the AC output terminal, screw the socket clockwise, and loosen the socket anticlockwise.

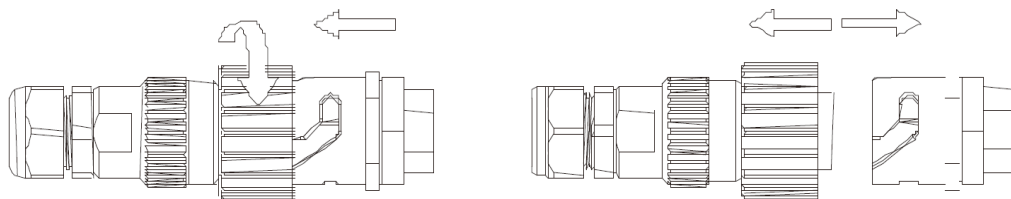

Be careful!

Please make sure that the wiring sequence of each cable is correct!

8.8. EPS Cable Connection

The terminal connection of EPS is the same as GRID terminal, but it's color is red. Please refer to connection method in 7.5.

8.9. Communication Connection

The inverter provides RS-485, WIFI, GPRS and other communication interfaces, and is equipped with a monitoring system, which can remotely browse the output voltage, current, grid frequency, fault and other information. At the same time, these parameters are stored in the local PC to facilitate the query of historical records.

8.9. 1 Assembling Connection

The RS485 and WIFI/4G share the same terminal, please avoid conflict when using. WiFi or 4G modules are optional when purchasing inverters The terminal definition is shown in the figure below:

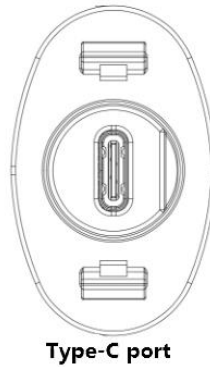

A1	A2	A3	A4	A5	A6	A7	A8	A9	A10	A11	A12
GND			VCC		A	B		VCC			GND
GND			VCC		B	A		VCC			GND
B12	B11	B10	B9	B8	B7	B6	B5	B4	B3	B2	B1

Pin	Name	Description
A4,A9,B4,B9	VCC	The power DC 5V of WIFI/4G module
A1,A12,B1,B12	GND	The power DC 5V of WIFI/4G module
A6,B6	RS485-A	The A line of RS485 with WIFI/GPRS/PC
A7,B7	RS485-B	The B line of RS485 with WIFI/GPRS/PC

There are three ways to connect the inverter:

- 1).By using WiFi module to communicate with the inverter, users can view information about the inverter on mobile devices or websites.
- 2).By using the 4G module to communicate with the inverter, users can view information about the inverter on their mobile devices or websites.
- 3).By using the computer to communicate with the inverter, users can purchase a special transfer module to connect with the computer. After downloading the upper computer from the official website, they can view the information of the inverter

8.10. Meter Connection

When the inverter is connected to the grid, it must be connected to the supporting electricity meter. Refer to section 1.1.2 for L/N connections. The inverter is connected with the electricity meter through RS485 communication mode. The wiring of the electricity meter is shown in the figure below:

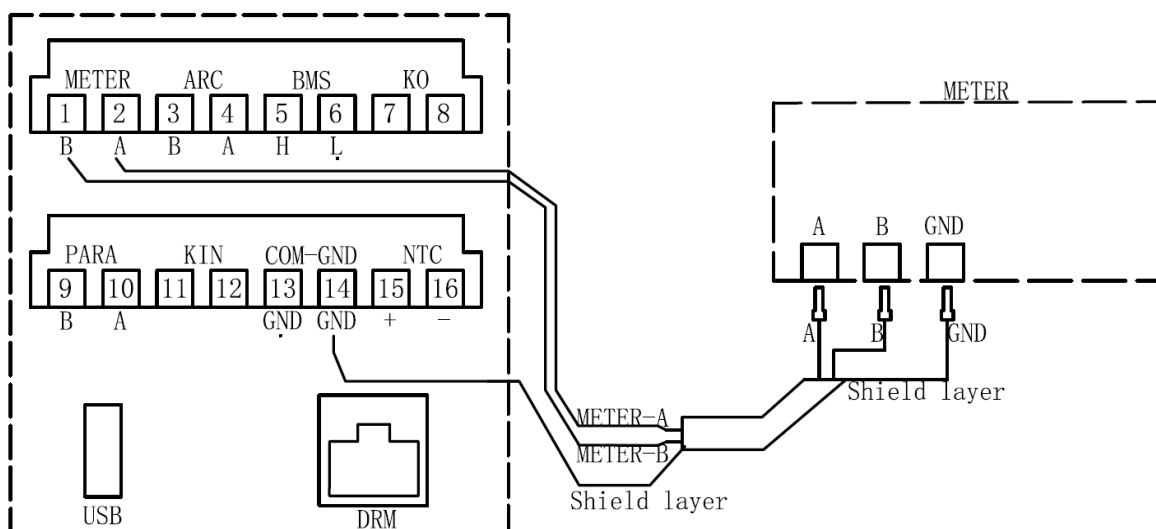

The meter mode is: SDM630MCT(40mA)

The meter manufacture is: EASTRON

8.11. Generation Limit and Export Limit Control

User can set the mode through the following steps Generation Limit and Export Limit Control, These two functions are in accordance with of AS/NZS 4777.2:2020 section 6.

Be careful!
TO use this setup, the meter must peproperly connected

8.11.1. Soft export Limit Control

Users can set the output power of the inverter through THE LCD (Soft export Limit Control); The operation steps are as follows:

Step 1: Press the "Enter" button in the main interface to ENTER the interface below, select the "Settings" option through the "Up" button and the "Down" button, and then press the "Enter" button to ENTER the next level menu.

Step 2: After entering the following menu, select the option of "Power regulation setting" through the "Up" and "Down" buttons, and then press the "Enter" button to Enter the next menu.

Step 3: After entering the following menu, enter the password through the "Up" button and "Down" button to enter the next menu. Power management information is an important parameter, in order to ensure the safety of users and set, password can be obtained by consulting customer service.

Step 4: After entering the password correctly, the user can access the following menu. You can use up or down keys to select "Soft Limit Control " and press ENTER. Press the up or down key to select "Export Limit Control " to limit the power output. After the Settings are

complete, OK is displayed. Press Esc to return to the home screen. The reference steps are shown below:

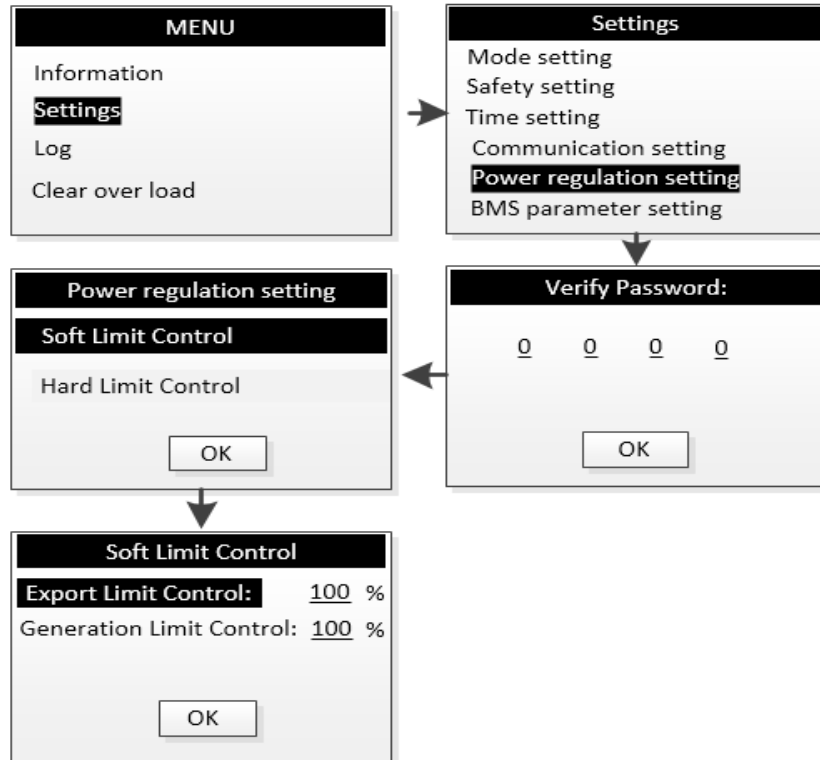

8.11.2 Hard export Limit Control

Users can set the output power of the inverter through THE LCD (Hard export Limit Control); The operation steps are as follows:

Step 1: Press the "Enter" button in the main interface to ENTER the interface below, select the "Settings" option through the "Up" button and the "Down" button, and then press the "Enter" button to ENTER the next level menu.

Step 2: After entering the following menu, select the option of "Power regulation setting" through the "Up" and "Down" buttons, and then press the "Enter" button to Enter the next menu.

Step 3: After entering the following menu, enter the password through the "Up" button and "Down" button to enter the next menu. Power management information is an important parameter, in order to ensure the safety of users and set, password can be obtained by consulting customer service.

Step 4: After entering the password correctly, the user can access the following menu. You can use up or down keys to select "Hard Limit Control " and press ENTER. Press the up or down key to select "Export Limit Control " to limit the power output. After the Settings are complete, OK is displayed. Press Esc to return to the home screen. The reference steps are shown below:

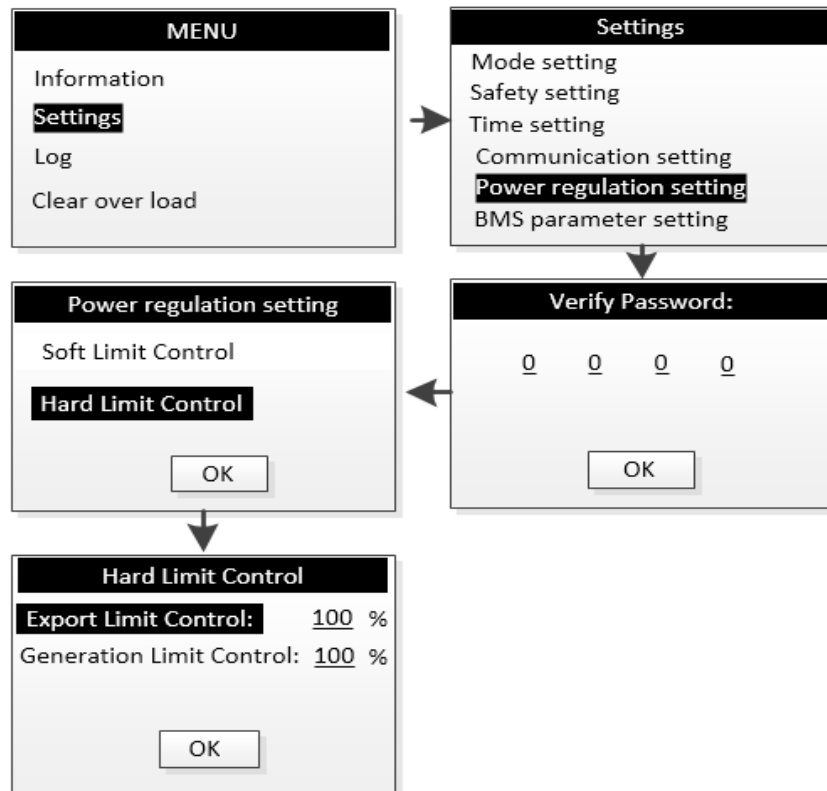

8.11.3 Soft generation limit control

Users can set the output power of the inverter through THE LCD (Soft generation limit control);
The operation steps are as follows:

- Step 1: Press the "Enter" button in the main interface to ENTER the interface below, select the "Settings" option through the "Up" button and the "Down" button, and then press the "Enter" button to ENTER the next level menu.
- Step 2: After entering the following menu, select the option of "Power regulation setting" through the "Up" and "Down" buttons, and then press the "Enter" button to Enter the next menu.
- Step 3: After entering the following menu, enter the password through the "Up" button and "Down" button to enter the next menu. Power management information is an important parameter, in order to ensure the safety of users and set, password can be obtained by consulting customer service.
- Step 4: After entering the password correctly, the user can access the following menu. You can use up or down keys to select "Soft Limit Control" and press ENTER. Press the up or down key to select "Generation Limit Control " to limit the power output. After the Settings are complete, OK is displayed. Press Esc to return to the home screen. The reference steps are shown below:

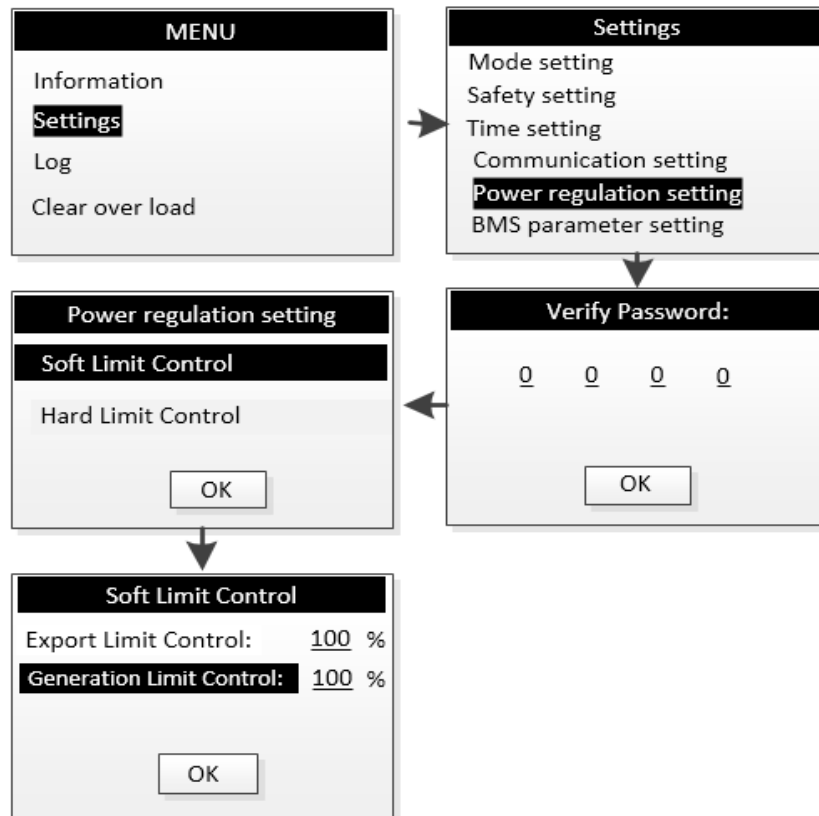

8.11.4 Hard generation limit control

Users can set the output power of the inverter through THE LCD (Hard generation limit control); The operation steps are as follows:

- Step 1: Press the "Enter" button in the main interface to ENTER the interface below, select the "Settings" option through the "Up" button and the "Down" button, and then press the "Enter" button to ENTER the next level menu.
- Step 2: After entering the following menu, select the option of "Power regulation setting" through the "Up" and "Down" buttons, and then press the "Enter" button to Enter the next menu.
- Step 3: After entering the following menu, enter the password through the "Up" button and "Down" button to enter the next menu. Power management information is an important parameter, in order to ensure the safety of users and set, password can be obtained by consulting customer service.
- Step 4: After entering the password correctly, the user can access the following menu. You can use up or down keys to select "Hard Limit Control" and press ENTER. Press the up or down key to select "Generation Limit Control" to limit the power output. After the Settings are complete, OK is displayed. Press Esc to return to the home screen. The reference steps are shown below:

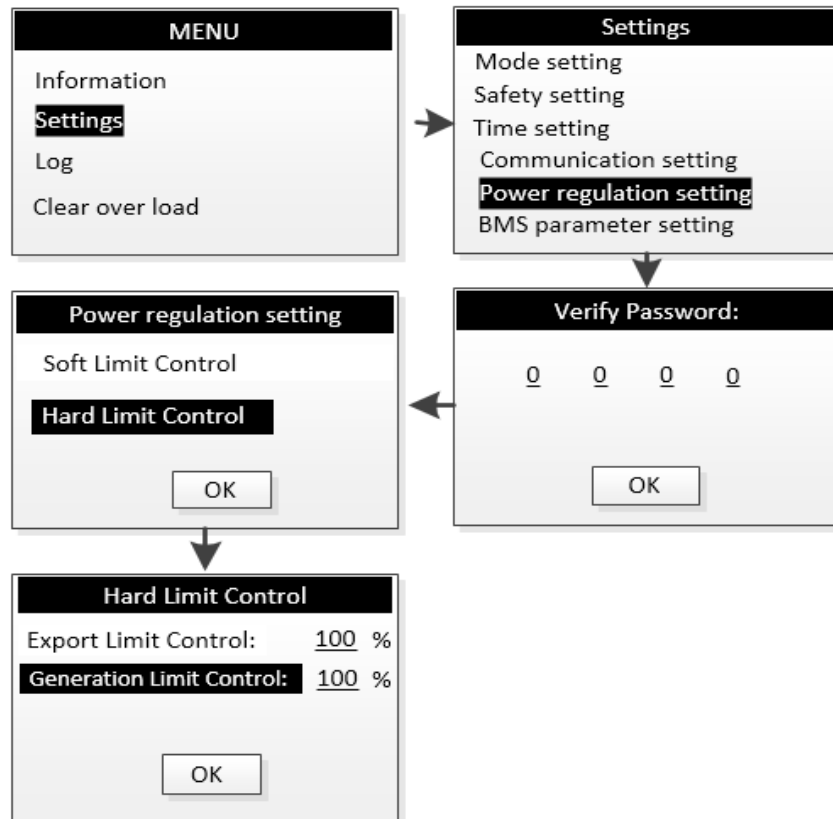

9. Commissioning

9.1. Inspection before Commissioning

Check the following items before starting the system:

1. The inverter DC switch and external circuit breaker are disconnected.
2. The inverter should be accessible for operation, maintenance and service.
3. Nothing is left on the top of the inverter or battery.
4. The inverter is correctly connected to the external devices, and the cables are routed in a safe place or protected against mechanical damage.
5. The selection of the AC circuit breaker is in accordance to this manual and all applicable local standards.
6. All unused terminals at the bottom of the inverter are properly sealed.
7. Warning signs and labels are suitably affixed and durable.
8. For EPS application, check the cable connections of inverter. Risk of inverter damage if the grid power wires are wrongly connected to the EPS terminals.

Can set the power quality mode through the following steps.

- Step 1: Press the "Enter" button in the main interface to ENTER the interface below, select the "Settings" option through the "Up" button and the "Down" button, and then press the "Enter" button to ENTER the next level menu.
- Step 2: After entering the following menu, select the option of "Power regulation setting" through the "Up" and "Down" buttons, and then press the "Enter" button to Enter the next menu.
- Step 3: After entering the following menu, enter the password through the "Up" button and "Down" button to enter the next menu. Power management information is an important parameter, in order to ensure the safety of users and set, password can be obtained by consulting customer service.
- Step 4: Enter the correct password, enter the following menu. The user can select the power quality mode to be set by "up" and "Down" (there are two modes, as shown in Figure 1), and then press "ENTER" to confirm. After the Settings are successful, the system displays OK, and press Esc to return to the home screen.

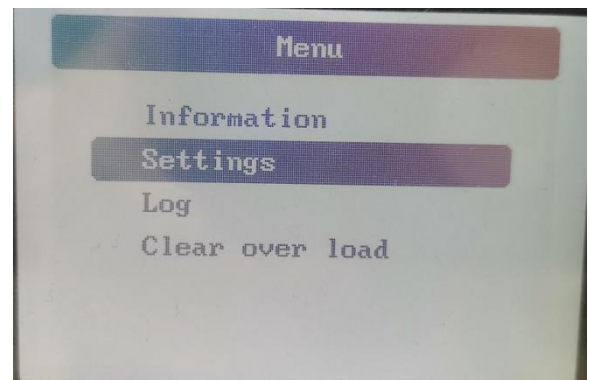
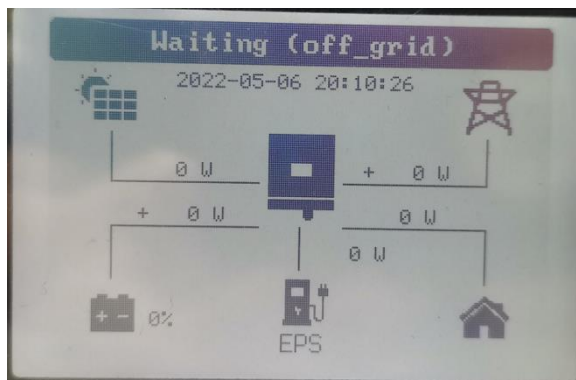

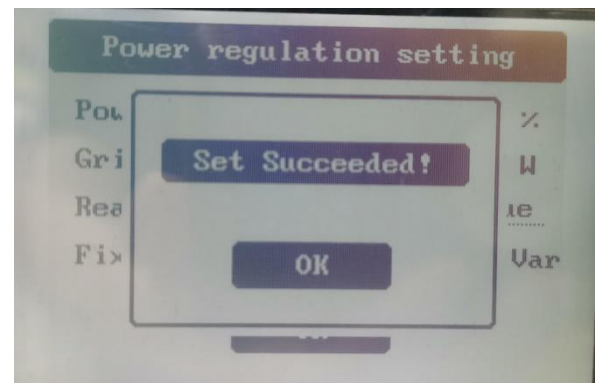
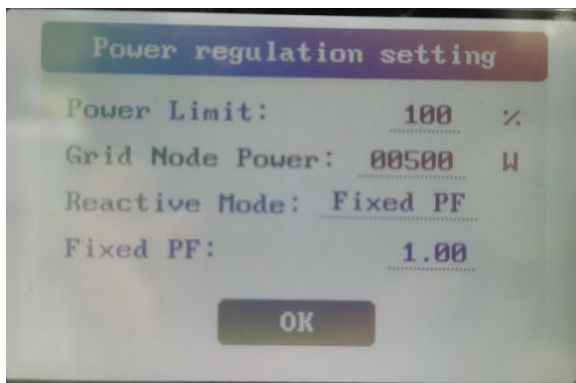
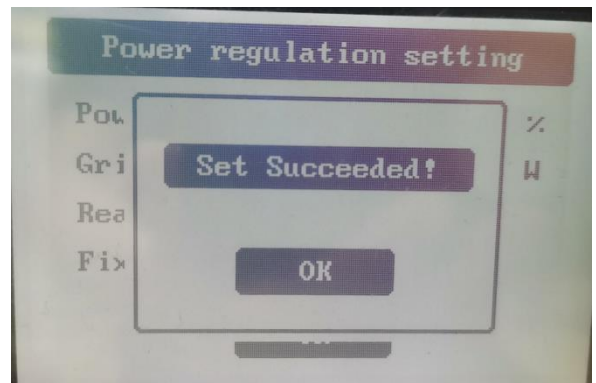
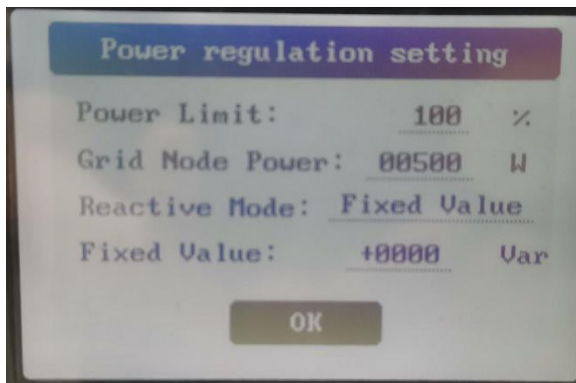
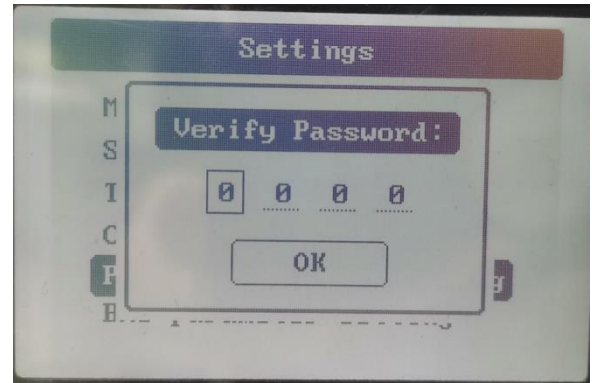
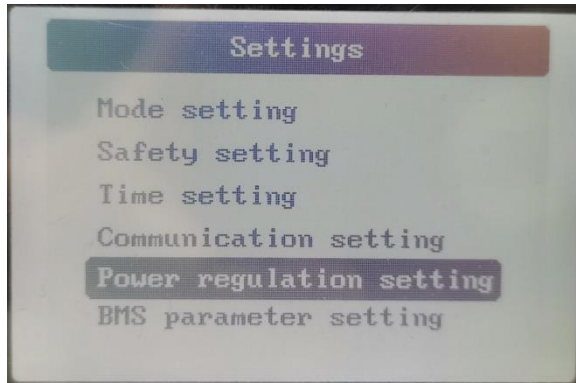

Figure

9.2. Powering on the System

Power on:

To turn on the inverter, the following steps must be performed in the order listed.

Step 1: close DC and AC circuit breakers;

Step 2: if the PV panel can provide enough power, the power module will work and light up the LCD panel;

Step 3: the inverter will enter the self-check mode, and the LCD will display the remaining reconnection time;

Step 4: when the inverter enters the normal mode, the power will be fed into the grid, and the LCD will display the power generation.

As long as the inverter operates normally, it will automatically track the maximum output power of photovoltaic cells. At night, the light intensity is not enough to provide energy, the inverter will automatically shut down. The next day, when the input voltage reaches the starting value, it will start automatically.



Be careful!

The surface temperature of the inverter can reach up to 75 °C

To avoid the risk of burns, do not touch the surface when the inverter is in operation mode.

In addition, the inverter must be installed out of the reach of children.

Shutdown:

To stop the inverter, the following steps must be performed in the order listed.

Step 1: Disconnect the AC switch.

Step 2: Wait for about 30 seconds (during which the capacitor on the AC side is discharged).

If the DC voltage of the inverter is higher than the starting threshold, the red power light will be on. Disconnect the DC switch.

Step 3: Confirm that all indicators are off (about 1 minute).



Be careful!

Although the inverter DC disconnect switch is in the off position and all indicators are off, the operator must wait 5 minutes to open the inverter housing after disconnecting the DC power supply.

9.3. LCD Introduction

When the LCD is displayed normally, the user can operate the keys to set the parameters and view them. The detailed menu flow chart is shown in Fig. 9-1.

The important parameters of the inverter must be set by professionals, otherwise it may cause the inverter can not operate normally. Please contact customer service for the password of setting parameters.

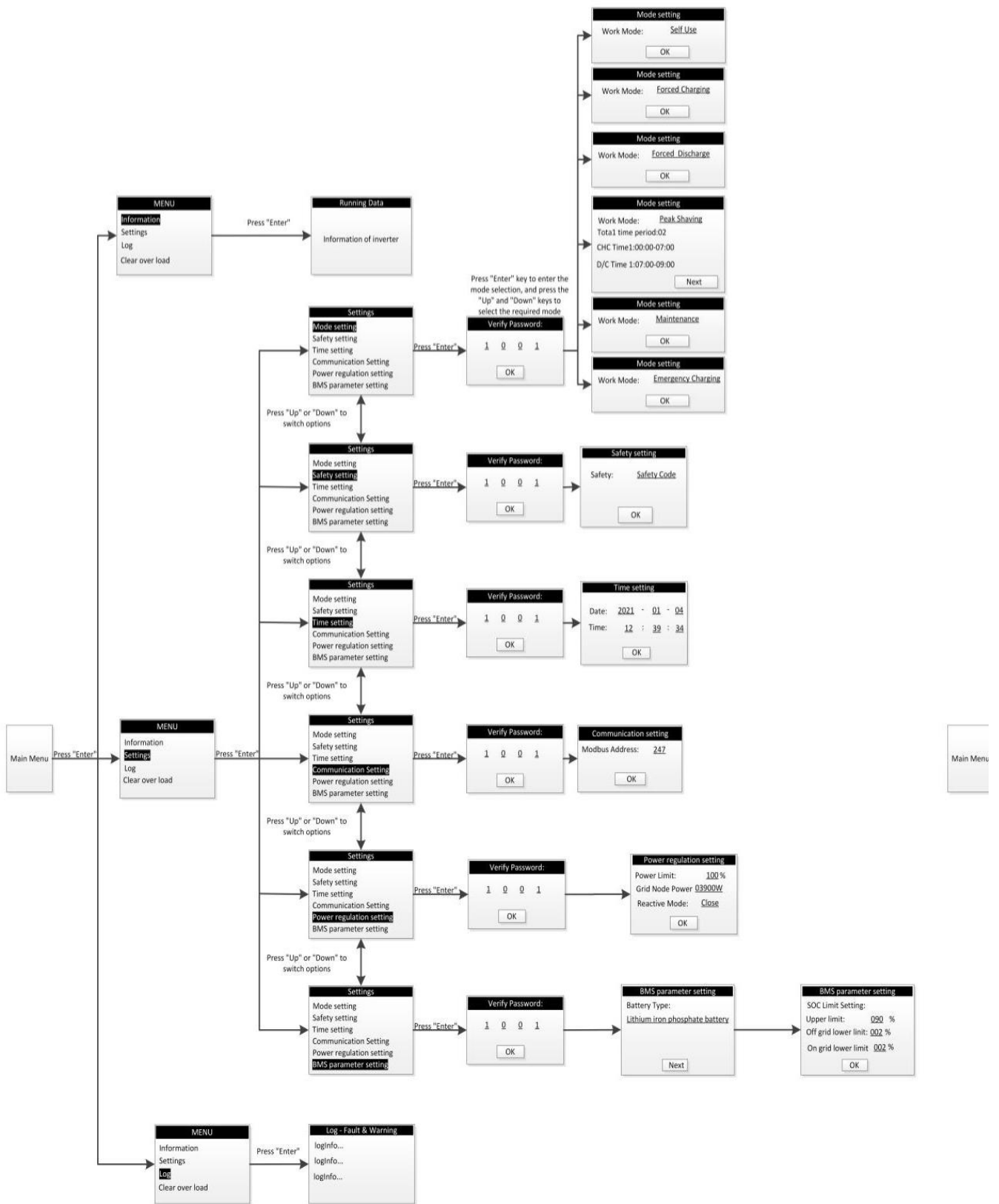

Fig. 9-1 LCD operating figure

10. Decommissioning

10.1. Decommissioning the Inverter

For maintenance or other service work, the inverter must be switched off.

Proceed as follows to disconnect the inverter from the AC and DC power sources. Lethal voltages or damage to the inverter will follow if otherwise.

10.1.1. Disconnecting the Inverter

1. Disconnect the AC circuit breaker and secure against reconnection.
2. Rotate DC switch to “OFF” position and disconnect all of the PV string inputs.
3. Disconnect the EPS circuit.
4. Disconnect the circuit between the battery and the inverter (turn off the BMS or DC switch in main circuit).
5. Wait at least **10** minutes until the capacitors inside the inverter completely discharged.
6. Remove the DC connector (PV and Battery).
7. Remove the AC connector and EPS connector.
8. Install the MC4 waterproof plugs and AC waterproof cover.

10.1.2. Dismantling the Inverter



Be careful!

Risk of burn injuries and electric shock!

Do not touch any inner live parts until at least 10 minutes after disconnecting the inverter from the utility grid and the PV input.

1. Refer to “7 Electrical Connection” for the inverter disconnection of all cables in reverse steps.
2. Dismantle the inverter referring to “6.2 Installing the Inverter” in reverse steps.
3. If necessary, remove the wall-mounting bracket from the wall.
4. If the inverter will be reinstalled in the future, please refer to “5.3 Inverter Storage” for a proper conservation.

10.1.3. Disposing the Inverter

Users should take the responsibility for the disposal of the inverter.



Be careful!

Some parts and devices of the inverter, such as the LCD display, batteries, capacitors, may cause environment pollution.

Do not dispose of the product together with household waste but in accordance with the disposal regulations for electronic waste applicable at the installation site.

11. Communication and Monitoring

11.1. Summery

The inverter provides an RS485 communication interface, which can be connected to WIFI/GPRS module. After configuring the monitoring system, the output voltage, current, grid frequency, fault and other information can be browsed remotely.

Port	Type	Protocl
Wifi	Type-c	Yes
USB	USB-A	Yes
RS485	Type-c	Yes
BMS	Terminal	Yes
DRM	RJ45	No

11.2. Communication

Users can browse the data of the inverter remotely through the RS485 communication interface. RS485 is usually used as local monitoring or connected to a third-party data collector: when connected to local monitoring, the RS485 interface of the inverter can be connected to the USB interface of the computer through the USB to RS485 converter. The longest RS485 line should not exceed 1200 meters. When networking and communication, a WIFI/GPRS communication module can be configured to realize the networking of communication.

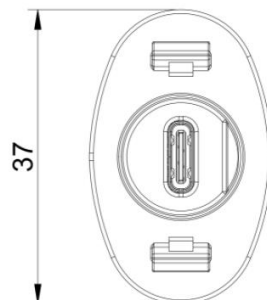

Pin	Name	Type	Describe	define	max value
A4,A9,B4,B9	VCC	Power Supply	DC 5V~12V	DC5V – 12V	DC 0.3V~16V -
A1,A12,B1,B12	GND	Ground	DC 0V	DC 0V	DC -0.3V
A6,B6	RS485-A	RS485 A line	-	-	-7V ≤ VCM
A7,B7	RS485-B	RS485 B line	-	-	≤ +12V



Be careful!

- Please connect RS485 in the correct line sequence.
- If the customer needs RS485 to communicate with the inverter, it is necessary to purchase a USB to RS485 converter.

11.3 RS-485 Communication

1. Through the purchase of type-C cable, transfer to 485 to USB communication line, and then connect to the computer.



2. Through the purchase of type-C cable, it is connected to the third-party RS485 to Ethernet switch.



3.If you need monitoring software, please ask the salesperson for it and consult usage method.



Be careful:

1. The wiring sequence of 2 terminals of 1 RS-485 cable shall be consistent.
2. If the customer needs RS-485 to communicate with inverter, they need to purchase USB to RS-485 converter.

11.4. WiFi / GPRS Communication

Can be configured with a WiFi / GPRS communication module to realize communication networking.The module is shown in the figure11-2 (there is no difference in appearance between WiFi module and GPRS module)



Figure 11-2

11.5 Monitoring

1. Local monitoring system

The local monitoring software is connected to the inverter through USB to RS-485 converter, and up to 32 inverters can be connected at the same time (it need to buy additional communication lines by yourself, and the settings are complex, which is not recommended for customers)

2. Remote monitoring system

- 1) Turn on the mobile wifi, select the WiFi module hotspot, and enter the password: 12345678(starts with EAFI module).Open the mobile browser and enter 10.10.10.1 to enter the WiFi module configuration page.The method is shown in Fig11-3.

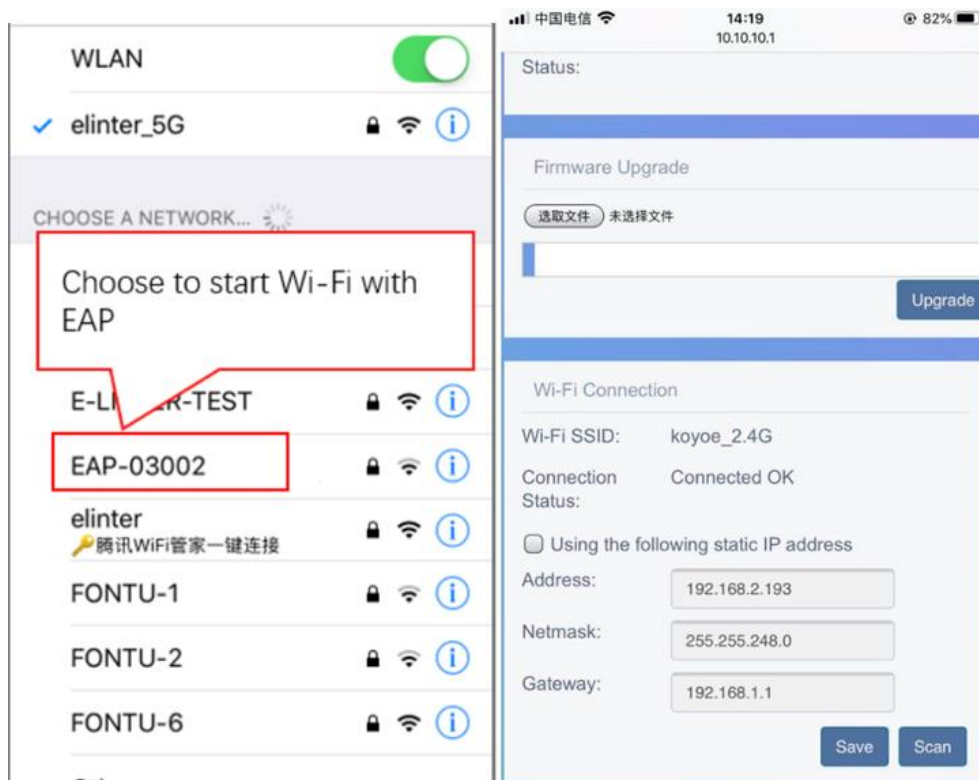

Figure 11-3

- 2) Click the "scan" button, and the router WiFi hotspot list will appear.Then select the WiFi hotspot, enter the password and click "connect".The method is shown in Fig11-4.

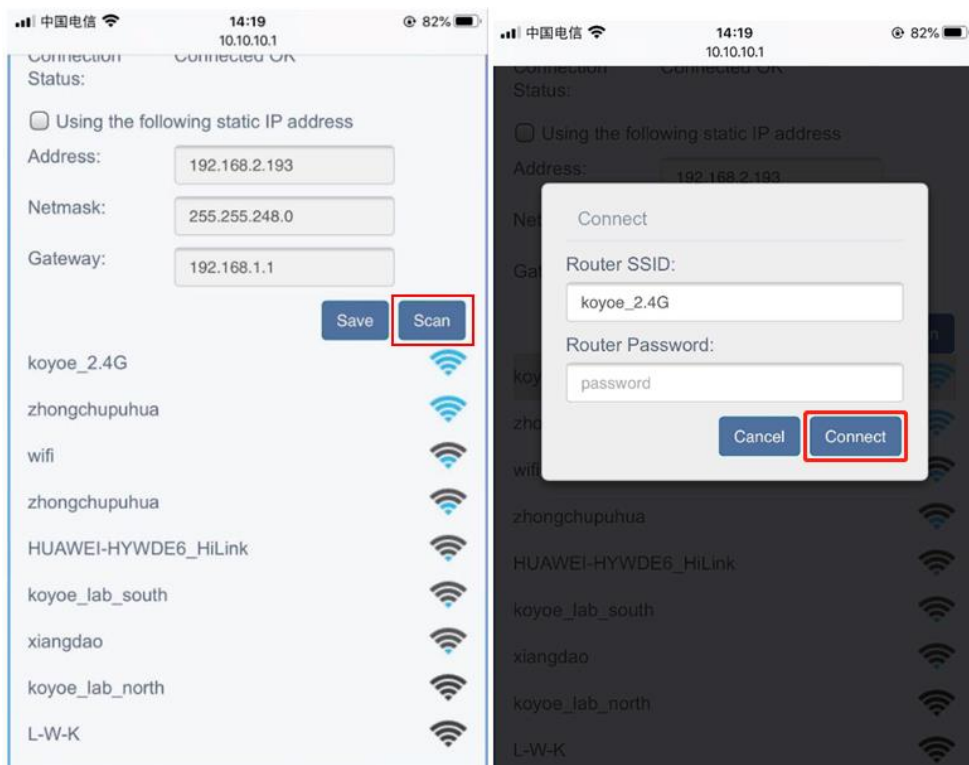

Figure 11-4

- 3.) In apple and android app stores, enter the KOYOE-log keyword, and users can download apps to your mobile device. After installation and registering an account, The method is shown in Fig11-5.

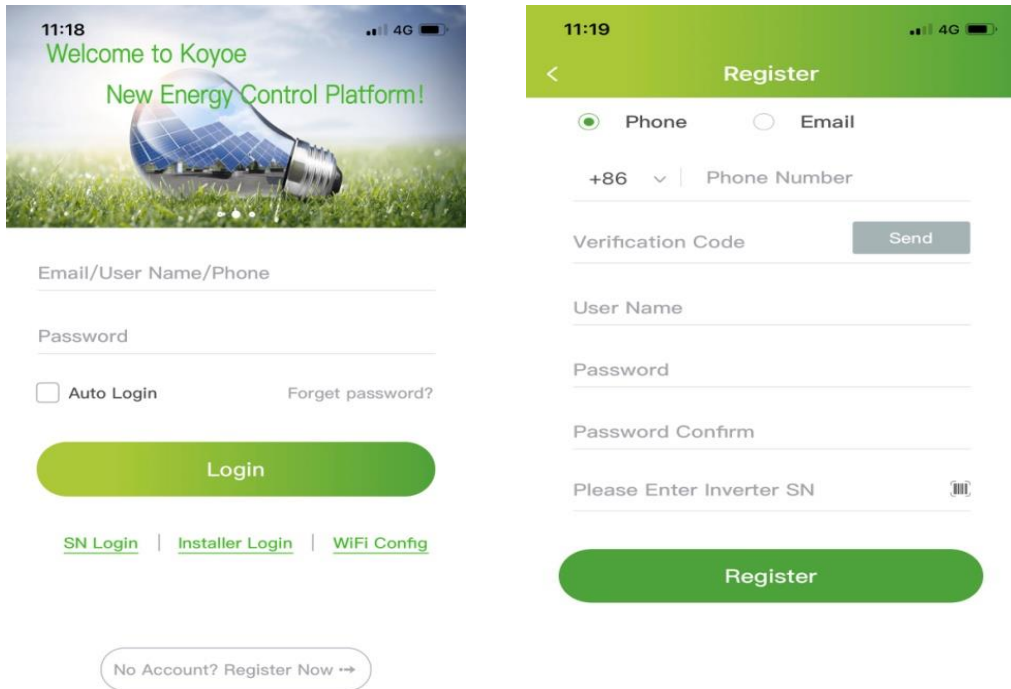

Figure 11-5

- 4) Enter the user name and password to log in, and the user can monitor the voltage, current and power of the inverter. (GPRS module only needs to fill in the SN code in Figure 11-4, and then click Register to monitor the data without the previous steps)

12. Maintenance and Repair

12.1. Precautions during Maintenance

When the inverter fails, the inverter will automatically disconnect from the grid and send fault or warning information. For solutions to simple faults, please refer to the common in Appendix I.

12.2 .Safety Requirements during Maintenance

For the operation running and after operation, the shell temperature is high due to the heat generated by power circuit, which is at risk of scalding. Contact operation shall be carried out after cooling.

Before removing the fault, it is necessary to ensure that the circuit breaker of DC or AC circuit is disconnected, and professional personnel are contacted to deal with it. Other people are not allowed to close the circuit breaker without authorization.

There is no repairable part in the inverter. If there is any problem, it must be maintained by professionals. Even if the inverter has been disconnected from PV and battery and power grid, it may still have dangerous voltage. Before starting work related to electronic system in the cabinet, the voltage of DC bus should be measured first. This voltage must be below 48V.

12.3. Daily Maintenance

Usually, the inverter does not need regular maintenance and calibration. Due to natural heat dissipation, the radiator must not be covered by dust and other dirt.

In order to ensure good ventilation of the inverter, it is necessary to check the radiator and make sure that it is unobstructed.

If necessary, clean the inlet and outlet of the inverter with a soft brush. Do not use water, corrosive chemicals or strong detergents to clean the inverter.

13. Technical data

13.1 .Technical Parameters And Certificates

6-10KW Three-Phase Hybrid Inverter				
Model		EST-6K0H	EST-8K0H	EST-10K0H
Efficiency	Max.Efficiency	>98.2%		
PV Input and Output	Max. PV input power(W)	7800	10400	13000
	Max. PV input voltage(V)	1000		
	MPP Operation Voltage Range(V)	180-900		
	Max. number of PV strings per MPPT	2PCS/(1+1)PCS	2PCS/(1+1)PCS	
	Max. PV input current(A)	12.5/12.5	12.5/12.5	
	Short-circuit current of PV input(A)	13.5/13.5	13.5/13.5	
	Start up voltage(V)	180		
Battery Input	Max Input/Output Voltage(V)	550		
	Operating Voltage Range(V)	180-550		
	Max Charge/Discharge Current(A)	25/30		
	Max Input/Output Power(W)	6000/6000	8000/8000	10000/10000
	Battery Type	Li-ion/Lead-acid		
AC Input and Output	Rated Power(W)	6000	8000	10000
	Max. Apparent AC Power(VA)	6000	8000	10000
	Nominal AC Voltage(Vac)	380,3L/N/PE		
	AC Power Frequency(Hz)	50/60		
	Max. AC Output Current(A)	10	12	15
	Rated Current Output(A)	10	12	15
	Power Factor Range	~1 (Adjustable from 0.8 leading to 0.8 lagging)		
	OutputTHDi(@Nominal Output)	<3%		
Off-Grid AC Output(Back-up AC Output)	Rated Output Power(W)	6000	8000	10000
	Max. Apparent AC Output Power(VA)	6000	8000	10000
	Nominal AC Output Voltage(Vac)	380,3L/N/PE		
	AC Power Frequency(Hz)	50/60		
	Max. AC Output Current(A)	10	12	15
General Data	Operating Temperature Range	-25°C ... +60°C(>45°C derating)		
	Operating Altitude(m)	<4000		
	Noise(dB)	<40		
	Topology	Transformerless		
	Cooling Method	Natural convection		
	Ingress Protection Rating	IP65		
	Relative Humidity	0-100%, no condensation		
	DC Connection Type	MC/Amphenol/Phoenix		
	AC Connection Type	Plug-in Connector		
	Display	LCD		
	Communication With Portal	RS485 (WiFi/GPRS Optinal)		
	Communication With BMS	CAN		
	Communication With Meter	RS485		
	Mounting Method	Wall-mounting bracket		
	Dimensions (W*H*D)(mm)	505*570*220		
	Weight(Kg)	23	23	24
Certification	Safety	IEC62109-1/-2		
	EMC	EN61000-6-1/-2/-3,IEC61000		
	On-Grid standard	AS4777.2,NRS097-2-1:2017		
Country of origin	Made in China			

12-20KW Three-Phase Hybrid Inverter					
Model		EST-12KH	EST-15KH	EST-17KH	EST-20KH
Efficiency	Max.Efficiency	>98.2%			
PV Input	Max. PV input power(W)	15600	19500	22100	26000
	Max. PV input voltage(V)	1000			
	MPP Operation Voltage Range(V)	180-900			
	Max. number of PV strings per MPPT	2PCS/(1+1)PCS	2PCS/(2+1)PCS	4PCS/(2+2)PCS	
	Max. PV input current(A)	12.5/12.5	12.5/23	23/23	
	Short-circuit current of PV input(A)	13.5/13.5	13.5/25	25/25	
	Start up voltage(V)	180			
Battery	Max Input/Output Voltage(V)	700			
	Operating Voltage Range(V)	180-700			
	Max Charge/Discharge Current(A)	50/50			
	Max Input/Output Power(W)	12000/12000	15000/15000	17000/17000	20000/20000
	Battery Type	Li-ion/Lead-acid			
AC Input and Output	Rated Power(W)	12000	15000	17000	20000
	Max. Apparent AC Power(VA)	12000	15000	17000	20000
	Nominal AC Voltage(Vac)	380,3L/N/PE			
	AC Power Frequency(Hz)	50/60			
	Max. AC Output Current(A)	18	22	25	31
	Rated Current Output(A)	18	22	25	31
	Power Factor Range	~1 (Adjustable from 0.8 leading to 0.8 lagging)			
	OutputTHDi(@Nominal Output)	<3%			
Off-Grid AC Output(Back-up AC Output)	Rated Output Power(W)	12000	15000	17000	20000
	Max. Apparent AC Output Power(VA)	12000	15000	17000	20000
	Nominal AC Output Voltage(Vac)	380,3L/N/PE			
	AC Power Frequency(Hz)	50/60			
	Max. AC Output Current(A)	18	22	25	31
General Data	Operating Temperature Range	-25°C ... +60°C(>45°C derating)			
	Operating Altitude(m)	<4000			
	Noise(dB)	<45			
	Topology	Transformerless			
	Cooling Method	Intelligent Fan			
	Ingress Protection Rating	IP65			
	Relative Humidity	0-100%, no condensation			
	DC Connection Type	MC/Amphenol/Phoenix			
	AC Connection Type	Plug-in Connector			
	Display	LCD			
	Communication With Portal	RS485 (WiFi/GPRS Optinal)			
	Communication With BMS	CAN			
	Communication With Meter	RS485			
	Mounting Method	Wall-mounting bracket			
	Dimensions (W*H*D)(mm)	505*630*220			
	Weight(Kg)	26	27	27	28
Certification	Safety	IEC62109-1/-2			
	EMC	EN61000-6-1/-2/-3,IEC61000			
	On-Grid standard	AS4777.2,NRS097-2-1:2017			
Country of origin	Made in China				

Other safety and protection is shown below:

Safety and Protection	YES/ON
Over/under voltage protection	YES
DC isolation protection	YES
Monitoring ground fault protection	YES
Grid protection	YES
DC injection monitoring	YES
Back feed current monitoring	YES
Residual current detection	YES
Anti-islanding protection	YES
Over load protection	YES
Over heat protection	YES

14. Warranty commitment

In order to provide you with high-quality service and better protect your rights and interests, please read this regulation carefully and keep your quality assurance card and purchase invoice.

We will provide you with standard warranty service for 5/10years (The warranty is 5 years and can be extended warranty to 10 years at most) From the date of purchase, during the warranty period, we will provide you with free warranty and maintenance services. The faulty inverter needs to be returned to the factory for repair, so please keep the original package properly. If the customer uses the new packing box, the packing cost and transportation cost will be borne by the customer. During the warranty period, the customer needs to provide the original invoice and quality card, and the label of the inverter body is clearly visible. If these requirements cannot be met, we will not be able to provide you with perfect service.

This regulation is applicable to series photovoltaic grid connected inverter produced by KOYOE. All products purchased through regular channels shall enjoy the full range of quality assurance services provided by the company, except for the following situations:

1. Beyond the warranty period;
2. No valid quality assurance card and product serial number;
3. Transportation damage;
4. Improper use, operation and modification;
5. Operating in an environment beyond the specified in this manual;
6. Any installation and use beyond the scope specified in relevant international standards;
7. Damage caused by abnormal natural disasters (earthquake, fire, flood, etc.).

15. Contact Information

If you have any questions about the PV grid connected inverter or technical issues, please contact us:

Jiangsu KOYOE Energy Technology Co., Ltd

Address: NO. 40, Wangwu Road, Wuzhong District, Suzhou Province, China

Tel: +86 512 6513 9208

Email: sales_int@koyoe.com

Web: www.koyoe.com

Appendix I: Common Problems

In case the inverter will not work normally at times, solutions to common problems are listed below. This will help technicians understand problems and take effective measures.

Item	LCD display	Possible Causes and Solutions
1	GFCI Fault	<ol style="list-style-type: none"> 1. The grounding current is too high. 2. After disconnecting the AC side circuit, pull out the photovoltaic cell at the input end and detect the peripheral equipment of the AC system. 3. After removing the fault, reconnect the PV panel and AC side circuit to detect the inverter status.
2	BMS Communication Fault	<ol style="list-style-type: none"> 1. Communication between the battery pack and the inverter failed. 2. Check whether the communication cable is connected correctly and reliably. 3. Restart the inverter after replacing the connecting cable.
3	SPI Communication Fault	<ol style="list-style-type: none"> 1. Master-slave DSP communication failure, please restart the inverter. 2. If it cannot work properly after reboot, please contact customer service
4	PV Overvoltage Fault	<ol style="list-style-type: none"> 1. PV overvoltage fault, please check the PV input voltage, voltage value must be less than 1000V.
5	Isolation Fault	<ol style="list-style-type: none"> 1. Check whether the inverter is effectively earthed and whether the impedance between the positive and negative poles of the photovoltaic cell is greater than 1M Ω; 2. Check whether the AC side is connected to the earth.
6	Grid Voltage Fault	<ol style="list-style-type: none"> 1. Please check whether the network voltage is too low or too high. 2. Restart the inverter after the power grid is normal
7	Grid Frequency Fault	<ol style="list-style-type: none"> 1. Please check whether the grid frequency is too low or too high. 2. Restart the inverter after the power grid is normal
8	Bus Voltage High	<ol style="list-style-type: none"> 1. Bus voltage is high, please check whether the PV input voltage is less than 1000V. 2. If the fault cannot be cleared after restarting the inverter, please contact customer service.
9	Off Grid Over Voltage Fault	<ol style="list-style-type: none"> 1. High off-grid output voltage. 2. Please check whether the off-grid port is connected correctly and whether the off-grid load is working normally.
10	Battery Over Temperature Fault	<ol style="list-style-type: none"> 1. Battery temperature is too high. 2. Please confirm whether the battery is placed in a high temperature area. 3. Please restart the inverter after the battery cools down.

11	Inverter Module Over Temperature Fault	1. High temperature of inverter module.2. Please confirm whether the heat sink of the inverter is blocked.3. Please confirm whether the working environment temperature of the inverter is normal.4. Restore the inverter after the surface temperature of the inverter cools.
12	Battery Voltage Low Fault	1. Low voltage battery failure. Please check the connection of the battery is correct.3. Please check whether the battery can work properly and restart the inverter.
13	Low ambient Temperature Warn	1. Low ambient temperature fault.2. Please confirm whether the ambient temperature of the inverter and battery is lower than the normal value, and restart the inverter after the ambient temperature rises.

In addition to the above common problems, if you encounter other unsolvable problems, please contact us, we will try our best to provide you with quality service.

Appendix II: Abbreviations of Terms

AC	Alternating Current
DC	Direct Current
DSP	Digital Signal Processor
EEPROM	Electrically Erasable Programmable Read Only Memory
EMC	Electromagnetic Compatibility
EMI	Electromagnetic Interference
GFCI	Grounding fault current leakage protector
HCT	Hall Current Transducer
LCD	Liquid Crystal Display
LED	Light Emitting Diode
MPPT	Maximum Power Point Tracking
PC	Personal Computer
PV	Photovoltaic
PVCS	Photovoltaic Control System
SCI	Serial Communication Interface